

University of California Santa Barbara
Environmental Health & Safety- Environmental Health Program
565 Mesa Rd. Santa Barbara, CA 93106
(805) 893-2471

NEW SWIMMING POOL PLAN APPROVAL REQUIREMENTS

This document contains requirements for submitting plans for a commercial pool owned by the University of California at Santa Barbara. It also contains basic requirements of the California pool code. For more detailed and specific information please consult a copy of the California Building Code, Title 24 and California Code of Regulations, Title 22.

PLAN AND SPECIFICATION REQUIREMENTS

Any person proposing to construct, reconstruct, renovate, alter, relocate or replace a public pool or change its ancillary facilities, mechanical equipment or related piping, shall submit legible plans and specifications to Environmental Health and Safety for review and written approval prior to commencing the work and in advance of the issuance of any building, plumbing, or electrical permits.

A valid California State Contractors License (C-53 Pool Contractor, or A Engineering) is required to construct public pools. A licensed architect or engineer may submit plans; however, the pool contractor must be identified prior to commencement of construction.

- A complete set of plans is required. This Department will retain one copy of the plans and specifications submitted for approval. Plans should include all items listed below.
- All equipment, materials, methods of construction, and design must be approved by this Department.
- All equipment shall be installed per manufacturer's instructions.
- Any changes in construction plans or equipment must be approved by this Department. Changes may require additional plan checks and resubmittal of plans.
- Pool plan approval does not authorize the violation of any law, ordinance, or regulation and final approval is subject to field inspection and evaluation. Written approval is required to open the pool for use.
- Plan approvals are valid for a period of two years from the date of approval.

CONSTRUCTION INSPECTIONS:

The project manager, contractor or architect shall notify this Department for the following inspections:

1. **Plumbing** (Pre-Gunite): Exposed plumbing and prior to applying gunite or applying pneumatically placed concrete;
2. **Pre-Plaster**: Prior to plastering or applying the final surface to the pool shell;
3. **Final**: At the completion of construction and any other inspections that may be required.

No pool shall be opened to the public without the written approval of the enforcing agent.

ITEMS TO BE INCLUDED (missing items may delay plan approval)

1. Job Address - street number, city, zip
2. Name, mailing address and telephone numbers of pool contractor and owner.
3. Scaled drawings (see diagrams and illustration at back of requirements)
 - A. Scale
 1. All pools other than spa pools, $\frac{1}{4}$ " = 1 ft. (top and profile view).
 2. Spa pools, $\frac{1}{2}$ inch or 1 inch = 1 ft. (top and profile view).
 - B. Top View
 1. Dimensions (length, width)
 2. Suction and return line plumbing sizes and type of material. Include location of skimmer(s), split suction drain(s), equalizers, and return lines.
 3. Four to 6 inch wide, slip-resistant tiles, of contrasting color, along the bottom of the pool where the water depth is 4½ feet. (Pools with a maximum water depth of 5 feet or less do not require a marking line)
 4. Stairs, ladders, grab rails, handrails.
 5. Location of depth markers.
 6. Contrasting tile on stair tread edges and spa bench edges, if used.
 7. Automatic fill line location.
 8. Pool light location(s), wattage, type, make, model.
 9. Emergency shut-off switch location for spa pools.
 10. Diving board (if any) location and distance from board center to side walls or other diving boards. (top view and side view) (See the pool code for dimension requirements for pools with diving boards)

- C. Profile View (longitudinal section)
1. Dimensions (length)
 2. Depths at the shallow end wall, depths at any beginning or ending in breaks in slope and depth at the main drain.
 3. Indicate depth markers on the pool deck to match depth markers on the wall.
 4. Stairs, with tread and riser dimensions.
 5. Dimensions of handrails, including height from deck and each step tread.
 6. Sectional view of coping.
 7. Water line tile (6", contrasting color, glazed/glossy smooth)
 8. Diving board (if any) with distance diving board extends over the pool and depths below the diving board.
- D. Plot Plan, Deck Details, and Pool Enclosure
1. Scaled plot plan showing pool location on property in relation to adjacent buildings.
 2. Equipment room:
 - a. Dimensions including ceiling elevation (at least 7'), placement of equipment and location in relation to the pool.
 - b. Lockable entrance.
 - c. Sloped floors to drainage (2%). Drain to sewer if indoors and to storm drain if outdoors.
 - d. Hose bibb with approved backflow for cleaning the floors and equipment.
 - e. Backwash and sewer connection. Protected from rain intrusion, if outdoors.
 - f. Floor sink or utility sink. Protected from rain intrusion, if outdoors.
 3. Deck details.
 - a. Pool location on deck.
 - b. A minimum of 4 feet of unobstructed decking around pool (6 ft. between any two pools). Include American with Disabilities Act (ADA) lift location.
 - c. Clearances from pool edge to pool enclosure and clearances outside of pool enclosure.
 - d. Type of deck drainage, located at least 4 feet from coping.
 - e. Deck material
 - f. Depth markers and no dive markers. Where pool has a maximum depth of 6 feet or less, no diving markers on the deck adjacent to all deck depth markers.
 - g. Hose bibb locations supplied with potable water with approved backflow.
 4. Pool enclosure details
 - a. Show the pool with the proposed fence or building wall surrounding it. There should be no windows, patio walls, or doors of living units as part of the enclosure. Areas outside of the enclosure must be a public area. The fence enclosure cannot adjoin a private property.
 - b. Show a scaled profile view of all fences, gates, and doors. Include latch hardware details. Must be self-closing and self-latching.
 - c. Outline the entire enclosure with a yellow marker.
- E. Restroom Details: Note: Restrooms are required at the pool or adjacent to the pool. When restrooms are required, showers and drinking fountains are also required. At residential facilities, when travel distance to the furthest living quarter is less than 300 ft., restrooms are not required.
- a. Separate restrooms for men and women. Urinal(s) required in men's restroom.
 - b. Smooth, moisture resistant wall finishes throughout.
 - c. Floors must be concrete or similarly resilient surface extending upwards onto the walls at least 5" with an integrally coved junction and shall slope $\frac{1}{4}$ " per foot (2%) to floor drain(s).
 - d. Shower(s) with adequate drainage and hot (not $>110^{\circ}\text{F}$) and cold water (when not available in adjacent living quarters).
 - e. Hand lavatory with hot and cold water, a permanently mounted soap dispenser, and a single-service towel dispenser.
 - f. Toilets(s) and urinal(s).
 - g. Drinking fountain in pool area (when drinking water is not available in adjacent living quarters).
 - h. Separate locker/dressing facilities are required for all non-residential pool facilities.
- F. Safety equipment and Signs
1. Indicate location of signs
 2. Indicate location of body hook attached to a pole at least 12ft. in length
 3. Indicate location of life ring with rope attached. The rope must be as long as the width of the pool.
 4. Indicate location of pool test kit, DPD type and pH.
- G. Solar heater system detail, if being installed

H. General Data and Equipment List

1. Surface area of the pool in square feet.
2. Volume or total pool capacity in gallons.
3. Color of plaster or pool surface (White).
4. Filter: make, model, square footage, and maximum GPM (Gallons Per Minute).
5. Filtration pump: make, model, horsepower rating, and maximum GPM.
6. Additional pumps: make model number and horsepower rating (spas, attraction pumps etc.).
7. Skimmer(s): make, model number, and maximum GPM.
8. Influent pressure gauge placed after the pump but before the filter (usually found on top of the filter).
9. A vacuum gauge before the pump.
10. Chlorinator and pH Regulating System: make and model.
11. Chemical controller: make and model (for pH and disinfection control)
12. Flowmeter: make and model.
13. Lighting; make and model, watts or wattage equivalent.
14. Backwash plumbing to sewer with air gap. Separation tank for filters using DE or similar media.
15. Fresh water automatic fill line from a potable water source with approved backflow prevention device.
16. Suction drain covers / grates: make and model.
17. Emergency shut off switch for all spa pumps and blowers.

General Public Pool Requirements

1. All pools must be lined with white plaster or a smooth, waterproof, white interior finish, impervious to moisture. Samples are required for shell finishes not previously approved.
2. No letters, marking, or images are permitted on the pool shell other than required safety markings.
3. The pool must be constructed of reinforced concrete or a material equivalent in strength and durability **(See Figures and Tables #1 and #2 for dimension requirements)**
4. The pool must be lined with (6" wide) waterline tiles around the entire perimeter of the pool. Rim flow pools are permitted to have depth markers installed below the waterline, but as close as is reasonable to the waterline. Waterline tiles must be contrasting in color to the white pool shell and be glossy smooth and easily cleanable.
5. Depth markers of contrasting color are required on the pool wall at the water line on both sides, at the minimum and maximum depths, at the break in slope, and at both ends of the pool. Waterline depth markers are required to be glazed and easily cleanable waterline tiles. Depth markers are required on the pool deck corresponding to every depth marker at the water line and are required to be permanent, slip resistant, tile, concrete, or concrete-like. All depth markers must be marked with the letters, "feet" or "ft." and "inches" or "in". Painted letters or vinyl decals are not permitted. Depth marker numbers must be at least 4 inches in height and must be positioned to indicate the water depth accurate to the nearest 6 inches as measured from the pool floor to the middle of the skimmer opening. Exception; Spa and wading pools require at least 2 depth markers.
6. A ladder as a second means of exit is required at the deep end or area of a pool having a water depth greater than 4½ feet, and on both sides if the pool width exceeds 30 feet, every 100 feet.
7. Steps and step holds of ladders must have a minimum tread of 5 inches and minimum width of 14 inches. Step risers must be uniform and not exceed 12 inches. Grab railings must be provided at the top of both sides and extend over the coping or edge of the deck.
8. Stairs are required at the shallowest end of all pools greater than 1 ft. in depth to the deck. All pools with two shallow ends or any instance where the pool user will encounter a shallow, deep and shallow configuration as the pool user proceeds through the pool will be required to have stairs at one shallow end and a means of exit such as a ladder(s) at the other shallow end.
9. All stairs must be at least 24 in. wide. All risers must be no greater than 12 inches high. The top riser is considered that distance from the deck or coping, down to the first tread of the stair and the deck thickness/coping should be taken into consideration. The first tread below the deck must be at least 14 inches but not greater than 18 inches long. The remaining treads must be 12 inches but not greater than 16 inches long. If the top tread is convexly or triangularly shaped, it must have a radius of a minimum of 21 inches but not greater than 24 inches. All treads except for the top tread must be uniform. **(See Figures and Tables #5 Stair and Handrail Dimensions)**
10. At least one hand rail is required for all stairs. Spas require two handrails. The handrail must be between 28 inches and 36 inches above the deck and above each step tread as measured from the deck and the edge of each step tread to the top of the handrail. The handrail must extend into the pool, from the deck to the bottom step tread, but shall not extend beyond the bottom step. A minimum clearance of 3 inches between any handrail and step riser is required. The handrail may not extend onto the deck more than 2-2 ½ feet or obstruct the deck unnecessarily. **(See Figures and Tables #5 Stair and Handrail Dimensions)**
11. Coping on pools must extend out into the pool at least 1 inch but not more than 2 inches. The coping must be at least 1 inch thick but no greater than 2½ inches thick. The handhold of the coping shall be no greater than 9 inches above the waterline. All coping or cantilevered decking must be sloped at 1/4 inch per foot away from the pool. Handholds are required around the entire perimeter of the pool. A C-701 type of handhold for rim flow and fiberglass spa pools is required around the entire pool. **(See Figures and Tables #3 for illustrations of the requirements)**
12. A minimum 4 ft. wide, continuous, slip-resistant, non-abrasive deck area of concrete or concrete like material must be provided flush with the top of the pool and extend completely around the pool. Deck material must be approved by this Department. Wood decking or indoor-outdoor carpeting is not permitted. Deck measurements are made from the coping edge. The required decking around a pool must be free of all posts, columns, or other obstructions and extend at least 4 ft. behind any diving board, slide, or permanent handicapped equipment. There cannot be any changes in the deck elevation around the pool. All parts of the deck must drain naturally or to floor drains at a slope between 1% and 2% with no accumulations of water. The space between the coping and the deck must be sealed with an appropriate caulking. There must be a minimum distance of 6 feet between any two pools.

13. Separate men's and women's public toilet facilities are required at the pool area except when living quarters of the farthest pool user is greater than 300 ft. travel distance from the pool. The distance is the walking distance from the pool wall to the furthest unit and includes 10 feet for each floor of multi-story buildings. Urinal(s) are required in the men's restroom and in unisex restrooms. When restrooms and shower facilities are required, they must be at the pool or adjacent to the pool area and located not more than 100 ft. walking distance (same level) away and be easily accessible by pool users. If two pools are located on the same property and all living units are within 300 ft. walking distance to either pool, no toilet facilities are required. If restroom and shower facilities are not required, the facilities need not comply with the swimming pool code in regards to separate men's and women's facilities, urinals, and floor drains, but must be constructed so as to be readily cleanable and comply with State Building requirements.
14. For calculating the number of showers, toilets and lavatories, and drinking fountains, one pool user shall be considered for every 15 sq. ft. of pool surface area. Add multiple pools in the same area together.
- One shower with hot and cold water must be provided for every 50 pool users.
 - One lavatory with hot and cold water must be provided for every 80 pool users.
 - One toilet must be provided for every 60 women and one toilet and one urinal for every 75 men.
 - One guarded jet drinking fountain shall be provided for the first 250 pool users and an additional fountain shall be provided for each additional 200 pool users or fraction thereof.
15. Each pool must be provided with a separate recirculation and treatment system.
16. Each pump located on any type of pool shall be plumbed with at least two suction outlets. Suction outlets shall be separated by a distance of at least 3 feet, measured from the center of one suction pipe to the other. The suction drains must be plumbed with a "T" in the center that is hydraulically balanced. Each branch of the "T" must be the same size or larger than the main suction plumbing.

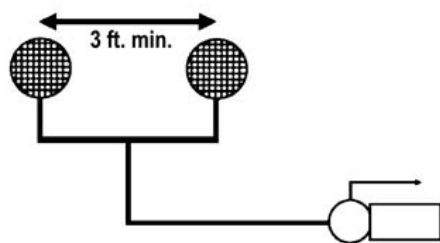

Dual Outlets

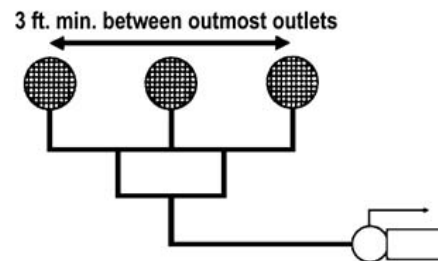

Three Outlets

17. In spa pools where room on the floor precludes both suction outlets from being on the floor, one suction outlet can be located on a wall or different design plane as long as the suction outlets are offset and separated by 3 ft. and the one on the wall's drain cover is within 3 in. of the floor. At least one filtration suction must be located on the floor.
18. Each suction cover of a split drain must be the same. The flow rating of each cover/grate shall be equal to or greater than the flow rating of the pump it is connected to. For example, if a pump is rated at 80 gpm at 60 feet of head, each cover/grate of the split suction must be rated at 80 GPM or greater. If 3 or more suction outlets are used, refer to the table below.

Number of covers/grates per system	Minimum flow rating of each cover/grate % maximum system flow rate
2	100%
3	66.7%
4	50%
5	40%
6	33.3%

19. Each branch of a split suction shall terminate under its own suction outlet. Except suction plumbing from two different pumps may terminate at one suction outlet, provided the combined flow rate of the two pumps is less than the flow rating of the cover/grate. See table above and diagram below.

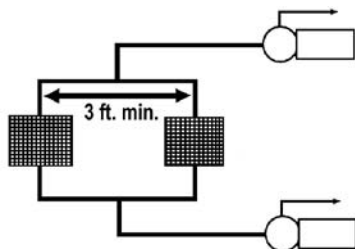

20. Split suctions must be plumbed so they are hydraulically balanced. See diagram below.

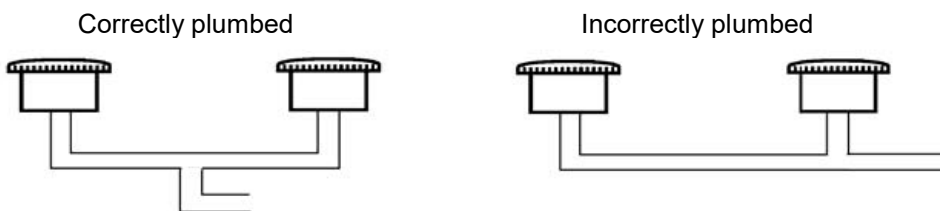

21. A main drain connected directly to a skimmer requires a split main drain.

22. Fasteners for suction fittings shall be designed so that tools are required for disassembly. Standard slotted screw drivers shall not be permitted for affixing covers to the suction fitting body. Fasteners shall be corrosion resistant and equivalent to grade 316 stainless steel.

23. If the drain cover/grate is not part of a pre-manufactured sump, and is placed on a field-built sump, the sump must comply with the following dimensions.

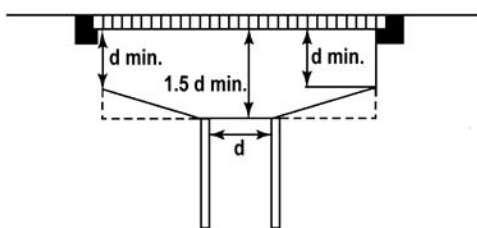

d = inside pipe diameter

24. The recirculation system shall have the capacity to provide a complete turnover of pool water in:

1. One-half hour or less for a spa pool;
2. One-half hour or less for a spray ground;
3. One hour or less for a wading pool;
4. Two hours or less for a medical pool;
5. Six hours or less for other types of public pools

25. One skimmer is required for every 500 square feet or less of pool water surface area or an adequate number to meet 100% of pump flow at the manufacturer's maximum flow rating, whichever is greater. A typical skimmer is rated at a maximum of 55-75 GPM.

26. Skimmers must meet the following requirements:

- a. Skimmers shall be built into the wall.
- b. Skimmers shall be individually adjustable.
- c. Skimmers shall have an air-lock protective device which will prevent leakage of air into recirculation system.
- d. Each skimmer shall have a cleanable screen or basket, removable from an opening on the deck.

27. If an equalizer is required, it must have an equalizer valve, be split at least 3 ft. apart, have approved covers, and be located at least 18" below the waterline.

28. Two return lines are required for the first 10,000 gallons and one return line for each additional 10,000 gallons. Return line inlets must be located at least 10 ft. apart, and at least 18" below the water line, except for spas and wading pools. For pools exceeding 40 ft. in width, or greater than 3,000 sq. ft. in surface area, bottom floor return lines are required.
29. Filters must be sized according to the following:
- | | |
|--------------------|---|
| Diatomaceous Earth | 2 GPM/sq.ft |
| Rapid Sand | 3 GPM/sq.ft. |
| High Rate Sand | 15 - 20 GPM/sq.ft. (see rating in equipment list) |
| Cartridge | .375 GPM/sq.ft. |
30. An influent pressure gauge placed before the filter but after the pump (usually found on top of the filter). An effluent pressure gauge is no longer required.
31. A vacuum gauge placed before the pump.
32. A flowmeter must be installed on a horizontal straight run of pipe with a minimum of 5 pipe diameters before and 2 pipe diameters after the flowmeter. It should be positioned after the filter and before the heater. It may be installed after the heater, if a great enough distance can be maintained so that heated water will not damage the flowmeter.

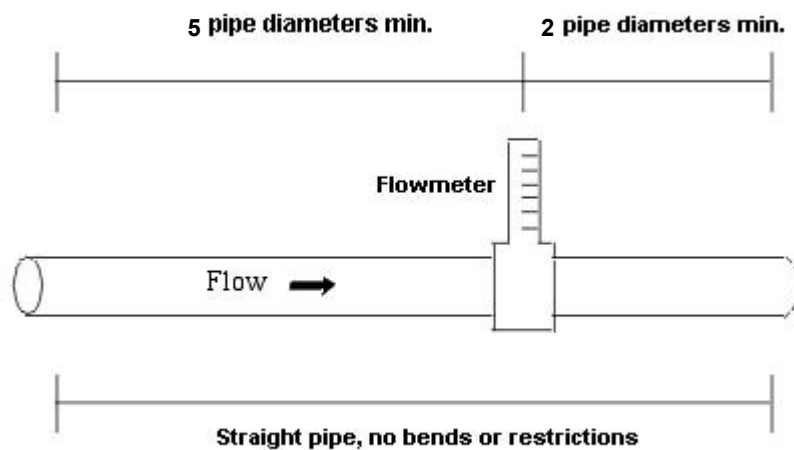

33. An automatic disinfectant and pH regulating system is required. Chlorinators are required to supply not less than the equivalent of 3 pounds of chlorine per day per 10,000 gallons pool water capacity.
34. A chemical controller is required to monitor and control the pH and disinfectant levels.
35. Chemical feeder pumps and recirculation system pumps are required to be electrically interconnected so that when the recirculation pump is off, chemical pumps are off.
36. Diatomaceous earth or similar filters must be permanently plumbed to a p-trap with a fixed air gap and have a separation tank. Sand filters must be permanently plumbed to a p-trap with a fixed air gap. A sight glass is required for observation of backwash water. Cartridge filters must have an area set aside with a hose bibb and floor drain to clean the filter. An extra cartridge filter is required to be available at the pool site.
37. No direct connection of a pool or its recirculating system shall be permitted with a sanitary sewer, storm drain or deck drain system.
38. The water velocity in all suction line plumbing shall not exceed 6 feet per second and in all return lines water velocity shall not exceed 8 feet per second.
39. Each pool must be provided with a split bottom drain by which the pool can be emptied.
40. A permanently installed fill line supplied by a potable water source and protected by an approved backflow device is required. The following backflow devices are required on fill lines of all pools and spas:
- Automatic fill lines with downstream valving - a pressure vacuum breaker.

- Fill lines connected to a filtration suction, return line, any pressurized line, or to equipment located below pool level - a reduced pressure (RP) principle backflow prevention device.

41. An adequate number of hose bibbs are required in the pool area in sufficient numbers to allow a 75 ft. hose to reach all areas of the pool deck. A hose bibb is required in the equipment area. Each hose bibb must be protected by an approved backflow device.
42. An underwater light is required in a swimming pool or spa. The light must be white (no color, or color changing) and at least 0.5 watts per square foot of pool or spa surface area. If a lighting type other than incandescent is used, such as fiber optic, fluorescent, halogen, or LED, their equivalency to incandescent lighting must be demonstrated.
43. The pool shall be enclosed by one or a combination of the following: a fence; portion of a building; wall; or other approved durable enclosure. Doors, openable windows, gates of living units or associated private premises shall not be permitted as part of the pool enclosure. The enclosure is required to meet all of the following specifications (**See Figures and Tables #3**):
 1. The enclosure shall have a minimum effective perpendicular height of 5 feet as measured from the outside.
 2. Openings, holes or gaps in the enclosure, doors and/or gates shall not allow the passage of a 4-inch diameter sphere. The enclosure shall be constructed over a hard and permanent material equivalent to concrete.
 3. The enclosure shall be designed and constructed so that it cannot be readily climbed by small children. Horizontal and diagonal member designs which might serve as a ladder for small children are prohibited. Horizontal members shall be spaced at least 48 inches apart. No planters or other structures that can be climbed shall be permitted within 5 feet of the outside of the pool enclosure or within a 5 foot arc of required clear space. The area 5 feet outside of the pool enclosure shall be a common area open to the public.
 4. Chain link may be used provided that the openings are not greater than 1¾ inches measured horizontally.
 5. The 5-foot areas outside the enclosure must be public areas, open to all patrons of the pool.
 6. A 5-foot clear radius is required outside of the fence enclosure with no trees, lamp posts, or any object that can be climbed.
 7. The enclosure cannot adjoin a private property. A 5-foot clearance is required from adjacent properties.
 8. The deck and ancillary facilities are required to be designed and intended to be used by pool users as defined as those engaged in water activity such as diving, swimming, or wading, or watching those engaged in water activity. All amenities for pool users within the pool enclosure, such as, fire pits, barbecues, and lounge areas, must be in view of the pool and also similar amenities are required to be provided outside of the pool enclosure for non-pool users.
44. Gates and doors opening into the pool enclosure also shall meet the following specifications:
 1. Gates and doors shall be equipped with self-closing and self-latching devices. The self-latching device shall keep the gate or door securely closed. Gates and doors shall open outwardly away from the pool except where otherwise prohibited by law. Hand activated door or gate opening hardware shall be located at a height no lower than 42 inches but no higher than 44 inches above the deck or walkway;
 2. Gates and doors shall be capable of being locked during times when the pool is closed. Exit doors which comply with Chapter 10, Title 24, California Code of Regulations shall be considered as meeting these requirements.
 3. The pool enclosure shall have at least one means of egress without a key for emergency purposes. Unless all gates or doors are so equipped, those gates and/or doors which will allow egress without a key shall have a sign in letters at least 4 inches high stating EMERGENCY EXIT.
 4. The enclosure shall be constructed so that all persons will be required to pass through common pool enclosure gates or doors in order to gain access to the pool area. All gates and doors exiting the pool area shall open into a public area or a walkway accessible by all patrons of the pool. No access to and from the pool area is permitted directly from private units or patios. No access to non-pool user amenities or rooms shall require passage through the pool area.
45. Supplemental heat transfer systems for pools or spas must not interfere with the proper functioning of the recirculation system or reduce the filtration rate below the required minimum. Heat exchangers must be installed according to requirements in the California plumbing code.
46. A body hook with a pole at least 12 ft. in length is required (not required for wading pools and spas). For public pools that exceed 75 feet in length or 50 feet in width, the pool operator shall provide a rescue pole and a life ring on at

least two opposing sides of the public pool at centralized locations.

47. A life ring with rope attached is required. The rope must be as long as the maximum width of the pool (wading pools and spas exempt). For public pools that exceed 75 feet in length or 50 feet in width, the pool operator shall provide a rescue pole and a life ring on at least two opposing sides of the public pool at centralized locations.
48. Plans are required to indicate the location of the required safety signs. The appropriate signs will be verified upon inspection as follows per code:
 1. REQUIRED SIGNS. All signs shall have clearly legible letters or numbers not less than 4 inches high, unless otherwise noted, fixed to a wall, pole, gate or similar permanent structure in a location visible to all pool users.
 2. POOL CAPACITY SIGN - A sign shall indicate the maximum number of pool users permitted for each pool. [In letters and numbers not less than 4 inches high]. The pool user capacity of a spa pool shall be based one pool user for every 10 square feet of pool water surface area. The pool user capacity for all other pools shall be based on one pool user for every 20 square feet of pool water surface area. Pool user capacity requirements do not apply to wading pools or spray grounds
 3. NO DIVING SIGN. Signs shall be posted in conspicuous places and shall state, "NO DIVING" at pools with a maximum water depth of 6 feet or less. [In letters not less than 4 inches high].
 4. NO LIFEGUARD SIGN - Where no lifeguard service is provided, a sign shall be posted stating, "NO LIFEGUARD ON DUTY." [In letters not less than 4 inches high].
The sign also shall state [in letters not less than 1 inch high], "Children Under the Age of 14 Shall Not Use Pool Without A Parent or Adult Guardian In Attendance."
 5. ARTIFICIAL RESPIRATION AND CARDIOPULMONARY RESUSCITATION SIGN - An illustrated diagram with text [not less than 1/4 inch high] of artificial respiration and CPR procedures shall be posted.
 6. EMERGENCY SIGN - The emergency telephone number 911, the number of the nearest emergency services and the name and street address of the pool facility shall be posted. [In letters and numbers not less than 1 inch high].
 7. SPA WARNING SIGN -A warning sign for spa pools shall be posted stating, "CAUTION" and shall include the following language [in letters not less than 1 inch high]:
 - a. Elderly persons, pregnant women, infants and those with health conditions requiring medical care should consult with a physician before entering the spa.
 - b. Unsupervised use by children under the age of 14 is prohibited.
 - c. Hot water immersion while under the influence of alcohol, narcotics, drugs or medicines may lead to serious consequences and is not recommended.
 - d. Do not use alone.
 - e. Long exposure may result in hyperthermia, nausea, dizziness or fainting.
 8. EMERGENCY SHUT-OFF SWITCH SIGN – [In letters not less than 1 inch high], a sign shall be posted at the spa emergency shut off switch stating, "EMERGENCY SHUT-OFF SWITCH."
 9. KEEP CLOSED SIGN - A sign shall be posted on the exterior side of gates and doors leading into the pool enclosure area stating, "KEEP CLOSED" [In letters not less than 4 inches high].
 10. DIARRHEA NOTICE SIGN - A sign [in letters not less than 1 inch high] and in a language or diagram that is clearly stated shall be posted at the entrance area of a public pool which states that persons having currently active diarrhea or who have had active diarrhea within the previous 14 days shall not be allowed to enter the pool water. This sign should be posted with all the other safety signs.
49. Floating type pool covers are limited to pools where there is constant supervision with a responsible person opening the pool and removing the cover and closing the pool each day. Floating type pool covers, permanently installed, and safety type pool covers must be submitted to this Department for approval, be ANSI approved, and must not obstruct the deck in any way and must not interfere with the coping requirements. Pool covers must be approved by this Department prior to use.
50. Tile used along the edge of the pool steps must be no greater than 4 inches wide, contrasting in color, and slip-resistant.
51. The direction of flow for the recirculation equipment shall be labeled clearly with directional symbols such as arrows on all piping in the equipment area. Where the recirculation equipment for more than one pool is located on site, the equipment shall be marked as to which pool the system serves. Valves and plumbing lines shall be labeled clearly with the source or destination descriptions.
52. All equipment rooms/areas must be easily accessible for inspection and have an enclosure that can be locked. If an enclosed room, the ceiling elevation must be at least 7 feet. A concrete slab is required with a floor drain. Floors are required to slope to drainage (2%), draining to the sewer if indoors and to the storm drain if outdoors. A hose bibb for cleaning the floors and equipment is required. A floor sink or utility sink protected from rain intrusion is required.

Pool Requirements

53. The maximum allowed water depth at the shallow end of a pool is 3½ ft. The water depth at the base of any portion of a stair must not exceed 3½ ft.
54. The minimum width of a swimming pool must be at least 15 feet wide, except for swimming pools with a maximum depth of 6 feet or less, the entire pool may be a minimum of 12 feet wide.
55. For areas of swimming pools with a depth greater than 6 ft., the width and length are required to be at least 15 feet wide at the deep end and 12 feet wide at the shallow end, the 15 ft. width must be at least 15 ft. long. Pools with curved shapes must have a minimum radius of at least 6 ft. at the shallow end and a minimum radius of at least 7½ ft. at the deep end.

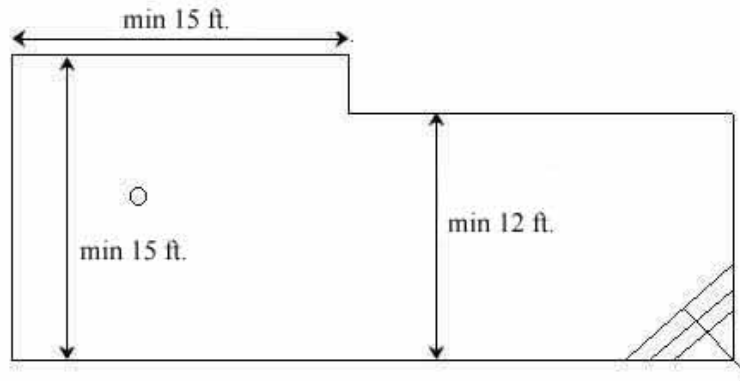

56. No recesses or projections are permitted in the swimming pool except as approved for stairs, handhold, ladders, steps, handrails, skimmers, inlet fittings, and perimeter overflow systems. An area is not considered a recess or projection, and will be permitted, if it is 12 ft. or more in length in a pool with a maximum depth of 6 feet or less or 15 ft. or more in length in a swimming pool with a maximum depth greater than 6 feet. Swimouts, loveseats, baja steps and foot holds are prohibited.

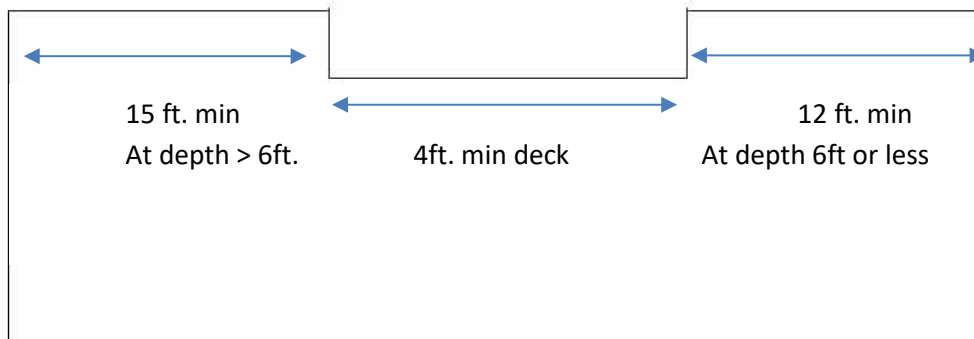

57. For "L" or irregularly shaped pools, the minimum width (12 ft. or 15 ft.), must be maintained for both sections of the "L."
58. For pools without diving boards, from the shallow end, to a depth of at least 4½ ft., the slope shall be no greater than 1 ft. vertically in 10 ft. horizontally. For a minimum distance of 3 ft., from the break in slope at 4 ½ ft. the slope shall not exceed 1 in 3. For a minimum distance of 3 ft. from the end of the 1-in-3 slope to the main drain, the slope shall not exceed 1 in 6. The main drain shall be a minimum of 3½ ft. from the deep end wall. **(See Figures and Table #1)**
59. In pools greater than 5 ft. in depth, a straight line of slip-resistant tile of contrasting color from the pool shell and lane markings must be installed on the bottom of the pool (not the walls) where the water depth is 4½ ft. The tile must be at least 4 inches but not greater than 6 inches wide.

ADDITIONAL REQUIREMENTS FOR SPAS

1. The water surface area of a spa must not exceed 250 sq. ft. and the water depth must not exceed 4 ft. The water depth over the benches must not exceed 24 inches.
2. All spas must have benches extending around the entire perimeter of the spa and have an aeration system sufficient to distribute aeration over the entire surface of the spa. Swim spas for general use are prohibited. In spas, because of size, where there is the possibility of someone swimming, the following sign may be required to be posted: "NO SWIMMING"- "It has been determined that swimming in elevated water temperatures may be hazardous to your health." There must be no abrupt changes in the height of spa benches. Any changes in spa bench elevation must not exceed a slope of 1:10. Medical spas may be exempt from some or all of the above requirements.
3. Spa benches must be a minimum of 12 inches but not more than 24 inches in width. The clearance between parallel benches in a spa must be at least 24 inches. Top surface edges of benches require tiles of contrasting color. The floors of spas are required to have a minimum length and width, or diameter of 24 inches. **(See Figures and Tables #2)**
4. A continuous unobstructed 4 ft. wide, slip-resistant, non-abrasive deck area of concrete or concrete like material must be provided flush with the top of the spa pool and extend around at least 50% of its perimeter. Spa steps must be located where the deck is at least 4 ft. wide. If the pool deck is raised more than 18" above ground level, it must have a protective railing extending around the entire perimeter, including areas not requiring a 4 ft. deck.
5. Landscape planters, flower beds, or similar unpaved areas shall not be located within 4 ft. of a spa pool unless such areas are behind a solid wall at least five feet in height as measured from the outside.
6. A spa pool aeration and/or hydro-jet system must be completely separate from its filtration system.
7. A return line will be required in a spa for each 50 GPM of designed filtration rate or fraction thereof (design rate means output of pump at 60 ft. of head) Example: if a spa has a required turnover rate of 78 GPM, it is required to have 2 return lines.
8. A spa pool must have a minimum of two depth markers. Slip-resistant depth markers are also required on the deck along with no diving tiles.
9. The maximum allowable water temperature of a spa shall be 104 degrees F.
10. Fiberglass or acrylic spas must be on the Los Angeles County Environmental Health Division's Approved Equipment List. Only white or light pastel colors are permitted. A light color is defined as a color having a light reflectance value (LRV) of 55% or greater. Tile samples for tile spas must be submitted for slip-resistance and color approval.
11. Fiberglass spas with coping as part of the pool shell extending out onto the deck shall have the following dimensions:
 - The height shall be at least 1/2 inch but not more than 2 inches above the deck.
 - The width shall be at least 2 inches and not exceed 6 inches. The surface of the coping must be slip-resistant and level (no slope). **(See Figures and Tables #3)**
12. A single clearly labeled emergency (on/off type) shut off switch which is readily accessible and visible from the spa, and will shut off all filtration, booster and blower pumps, is required.
13. Waterline tile of contrasting color around the entire perimeter of the pool is required.
14. Cold plunges are permitted under the following conditions:
 - The maximum size is 49 sq.ft. and the maximum depth is 4 ft.
 - The cold plunge must be built in conjunction with a hot spa.
 - The cold plunge must have a refrigeration system or other means to cool the water.
 - Recirculation system requirements must comply with hot spa standards.
 - A ladder and grab rail may be used in lieu of stairs.
 - Benches may be omitted.

ADDITIONAL REQUIREMENTS FOR GUTTER AND RIMFLOW POOL

1. A separate surge chamber is required.
2. Pools plans must be designed and approved by an engineer or architect with experience working on public pools.
3. A C-701 type handhold is required around the entire perimeter of a rim flow pool and the handhold is not permitted to protrude into the pool. **(See figures and Tables #3)**
4. The entire gutter must be accessible for cleaning. Rim flow pool gutter covers must be removable.

ADDITIONAL REQUIREMENTS FOR SOLAR HEATING

1. Solar panels and all components must meet National Sanitation Foundation (NSF) Standard 50.
2. Split suction outlets shall be located at the deepest section of the pool so that covers are within 3 inches of the pool floor and shall be no closer than 5 feet to any inlet.
3. Pipe velocity and sizing requirements must be met.

ADDITIONAL REQUIREMENTS FOR SPRAY GROUNDS

1. A minimum 4-foot wide walking surface shall extend around the perimeter of the splash zone of a spray ground.
2. The recirculation system shall be in operation at all times that the spray ground is open for use and shall have a minimum of four turnover cycles prior to opening for proper disinfection and filtration.
3. There shall be no standing water within the splash zone.
4. Nozzles that spray from the ground level shall be flush with the ground with openings no greater than ½ inch. Spray ground water features that extend above the ground must be clearly visible.
5. The splash zone shall be sloped so that only water from the spray ground water feature flows back to the surge basin. Areas adjacent to the splash zone shall be sloped away from the spray ground to deck drains or other surface water disposal systems.
6. All foggers and misters that produce finely atomized mists shall be supplied directly from a potable water source and not from the surge basin.
7. When multiple pumps are used the control systems for the spray ground water feature pump and recirculation system pump shall be electrically interconnected so that when the recirculation pump is off the spray ground water feature pump also is off.
8. The spray ground shall have a surge basin or treatment tank constructed of materials which are inert, corrosion resistant, nontoxic and watertight including materials such as concrete, fiberglass, high density polyethylene, stainless steel or other materials as approved by the enforcing agent which can withstand all anticipated loadings under full and empty conditions as determined by an engineer or architect who has experience working on public pools.
9. The total volume of the surge basin shall be at least 4,000 gallons or a minimum of three times the gallons per minute flow rate of all the spray ground pumps and the recirculation pump combined, whichever is higher.
10. The turnover time shall be one-half hour or less.
11. The suction intake for the spray ground or water feature pump in the surge basin shall be located adjacent to the recirculation return line.
12. When separate pumps are used, the suction intake for the recirculation pump shall be located in the lowest portion of the surge basin and on the opposite side from the suction intake for the spray ground pump.
13. The surge basin shall be designed to have easy access for cleaning and inspection. The basin shall have at least one ladder access and shall have at least one 3-foot by 3-foot access opening. Lids shall be locked or require a tool to open.
14. The surge basin shall be equipped with an automatic make up water fill device through an air gap or be protected by an approved backflow prevention device in accordance with Chapter 6 of the California Plumbing Code.
15. Ultraviolet light disinfection shall be used to supplement disinfection methods required in this chapter unless another treatment process is provided that has been determined by a nationally recognized testing laboratory to be capable of providing at least the equivalent level of reduction of cryptosporidium as the ultraviolet light disinfection system. The ultraviolet light disinfection unit shall comply with the applicable requirements established by the NSF/ANSI 50-2010 performance standard effective August 2010.

16. An accurately calibrated ultraviolet light intensity meter that has been properly filtered to restrict its sensitivity to the disinfection spectrum shall be installed in the wall of the disinfection chamber at the point of greatest water depth from the light source.
17. The ultraviolet light unit shall be located on the recirculation system and shall be installed to provide treated water directly to the spray features.
18. The ultraviolet light disinfection system must be equipped with an automatic shutdown system that inactivates the water feature pump if the ultraviolet dosage rate drops below 40 mJ/cm².
19. Artificial lighting shall be provided at all spray ground pads which are used at night or which do not have adequate natural lighting so that all portions of the spray pad and deck may be seen easily. Lighting that may be exposed to the feature pool water shall be installed in accordance with the manufacturer's specifications and the California Electrical Code.
20. A means of diverting runoff from the splash zone shall be installed on the spray ground drainage piping before the surge basin to divert water to the storm drainage system when the spray ground is not in operation.
21. A removable and cleanable catch screen or basket shall be installed on the spray ground drainage system before it enters the reservoir to prevent larger debris.
22. A sign shall be posted at each spray ground and be visible from any part of the spray ground that states, "CAUTION: WATER IS RECIRCULATED. DO NOT DRINK."

Appendices

Figures and Tables

1. Dimension Requirements for A Pool Without Diving Boards 31-B3

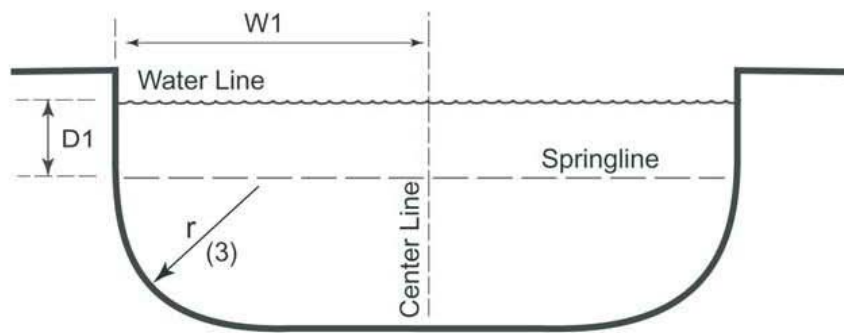
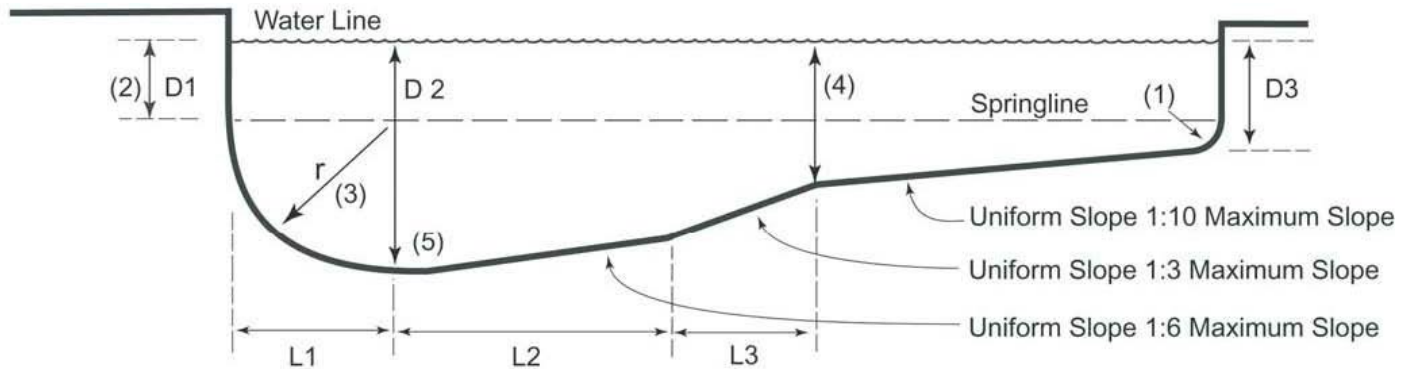

31B3-a POOLS WITH MAXIMUM WATER DEPTH = 6' 0"

Dimension	D1	D2	D3	L1	L2	L3	W1
Minimum	2' 6"	(5)	0' 0"	3' 6"	3' 0"	3' 0"	6' 0"
Maximum	—	6' 0"	3' 6"	—	—	—	—

31B3-b POOLS WITH MAXIMUM WATER DEPTH > 6' 0"

Dimension	D1	D2	D3	L1	L2	W1
Minimum	2' 6"	(5)	0' 0"	3' 6"	3' 0"	7' 6"
Maximum	—	—	3' 6"	—	—	—

Notes for Figure 31B-3 and Tables 31B-3a and 31B-3b.:

1. Radius at the shallow end shall be a minimum of 0' 6" and a maximum of 1' 0".
2. Springline D1 shall extend to the break in slope between the shallow area and deep area.
3. Maximum radius shall equal D2 minus D1 dimensions.
4. Where there is a break in slope, the break shall be located at a water depth equal to 4' 6".
5. The main drain shall be located to provide complete drainage of the pool

2. Spa Pools

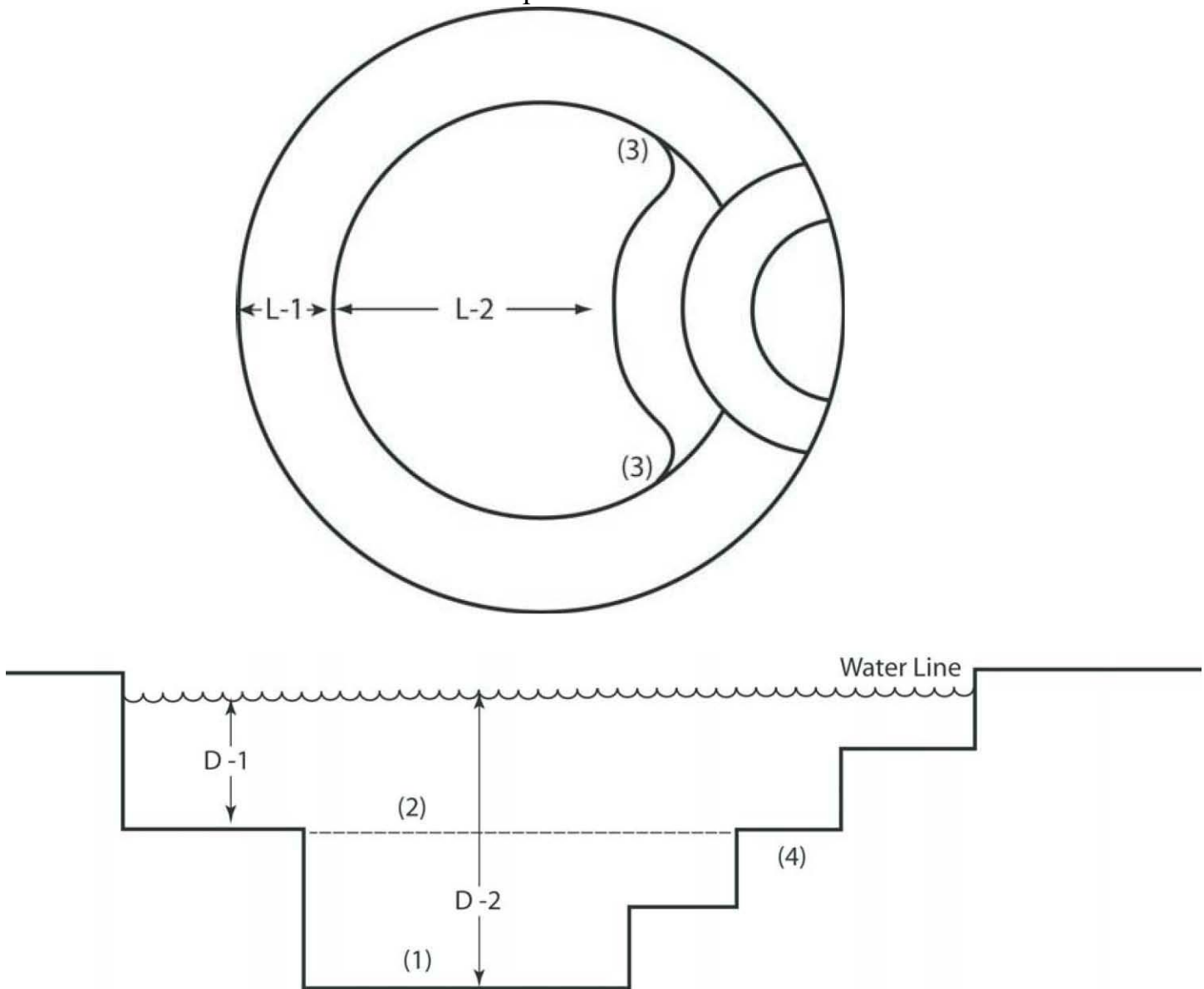

1. Bottom slope shall not exceed 1:10 and must be uniform. D-2 not to exceed 42" at base of stairs.
2. Bench ramping shall not exceed 1:10 uniform slope, measured at the inner circumference of the bench.
3. Six-inch minimum radius at "pinch points."
4. See #5 Stair and Handrail Dimensions

3. Coping

Dimension	Depth of Water		Length of Sections	
	D1	D2	L1	L2
<i>Minimum</i>	---	24"	12"	24"
<i>Maximum</i>	24"	42"	24"	---

3. Coping

APPROVED COPING

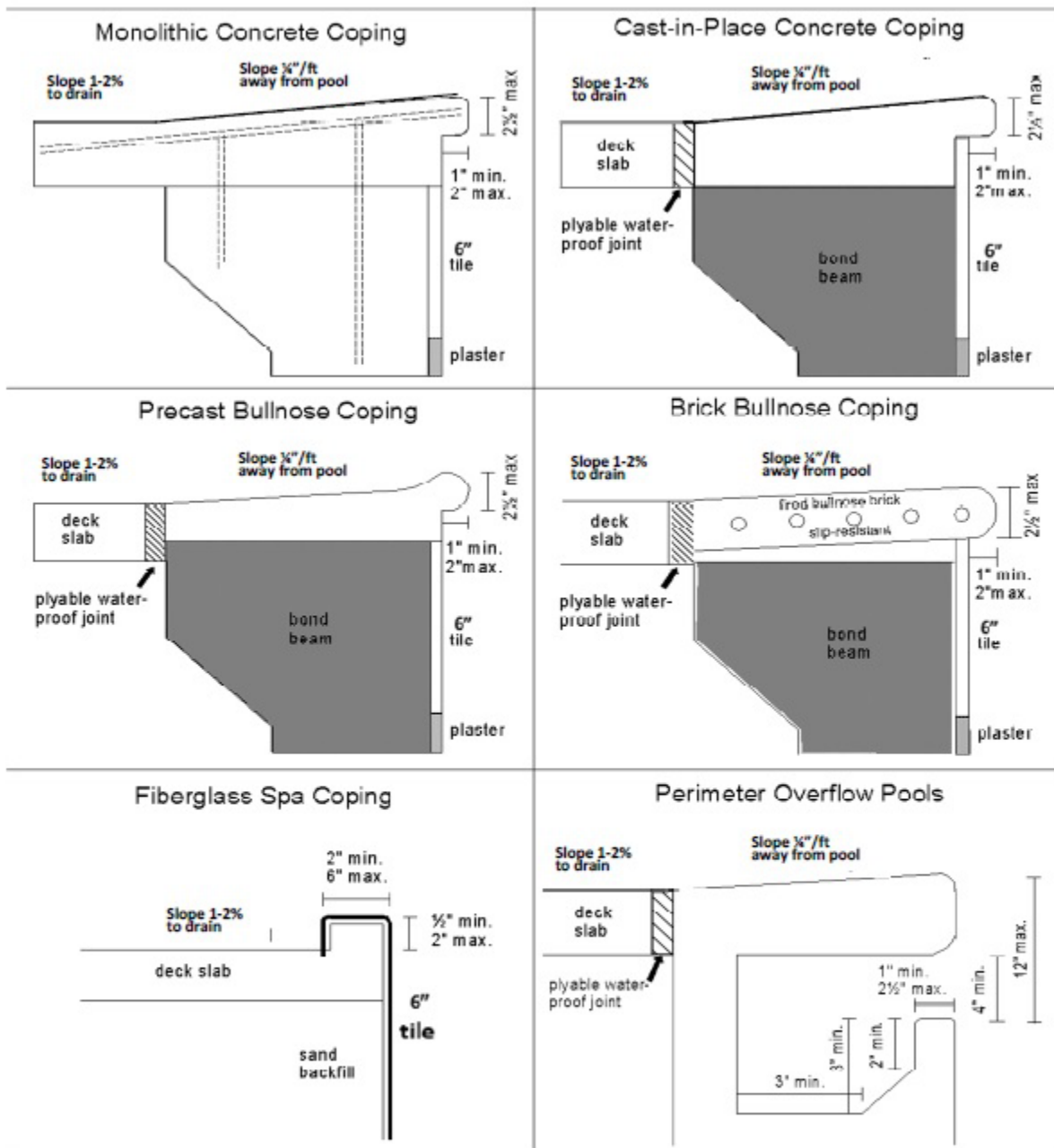

Rim Flow Pools (C701 type) Or Tile Spa

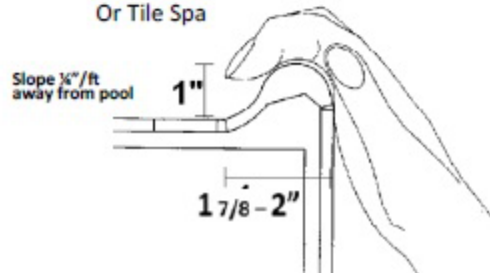

4. Fencing Dimensions

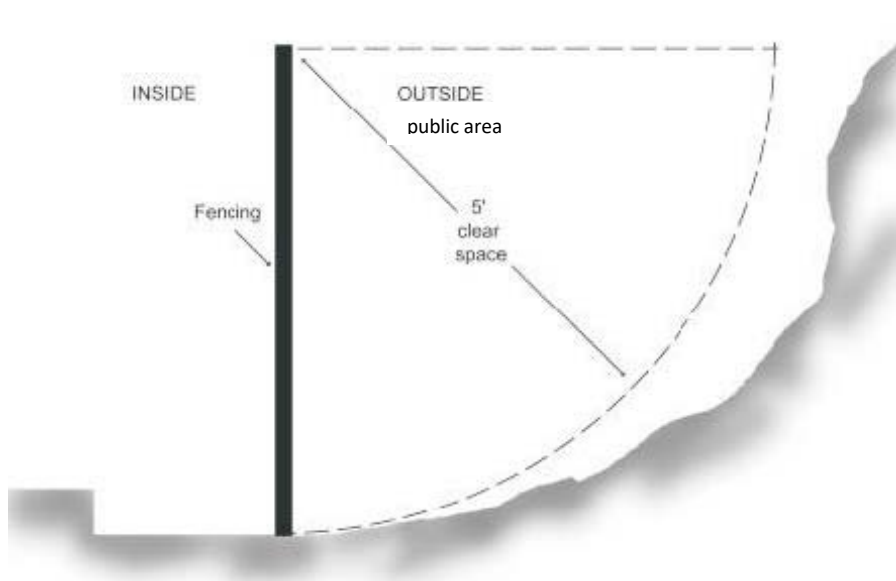
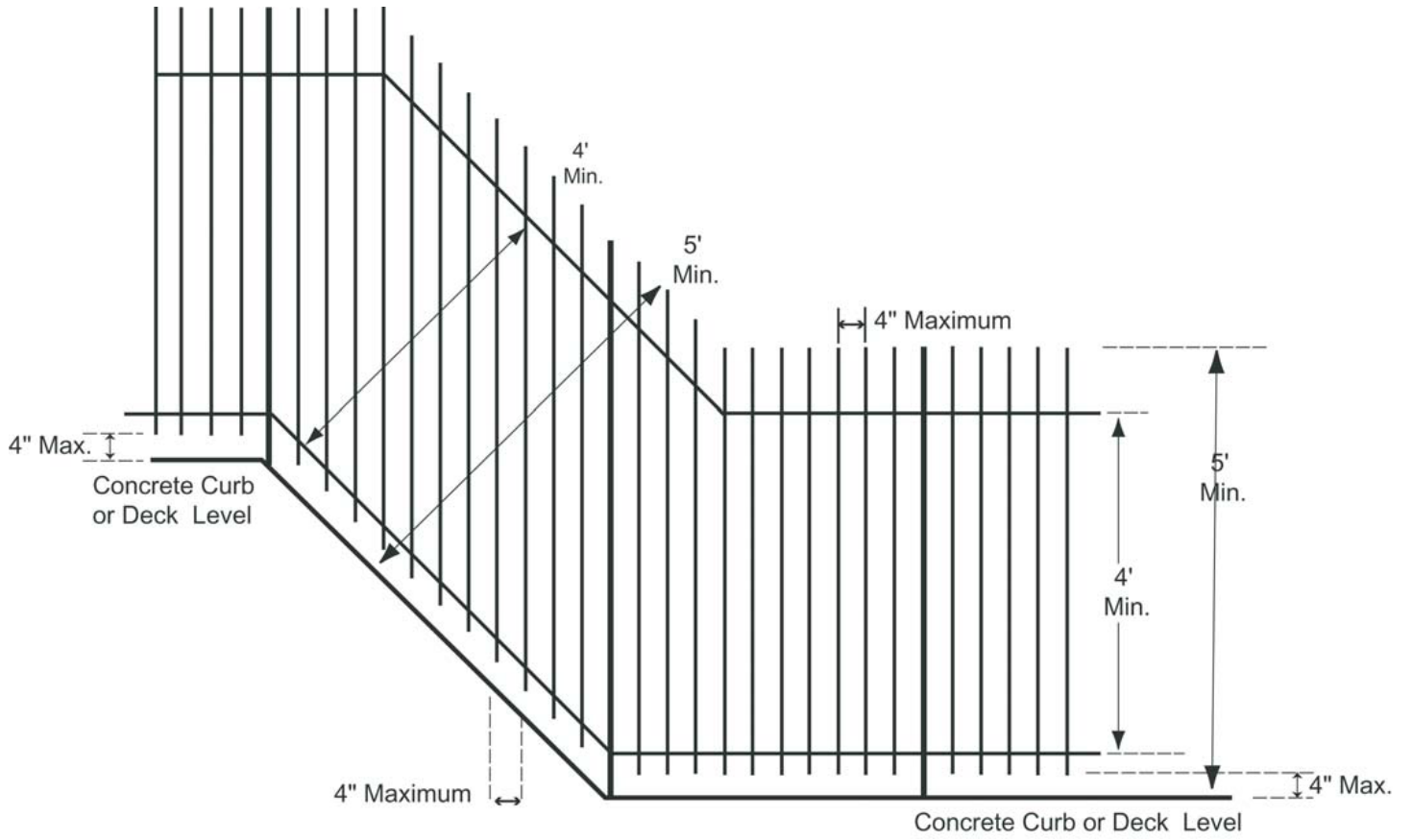

5. Stair and Handrail Dimensions

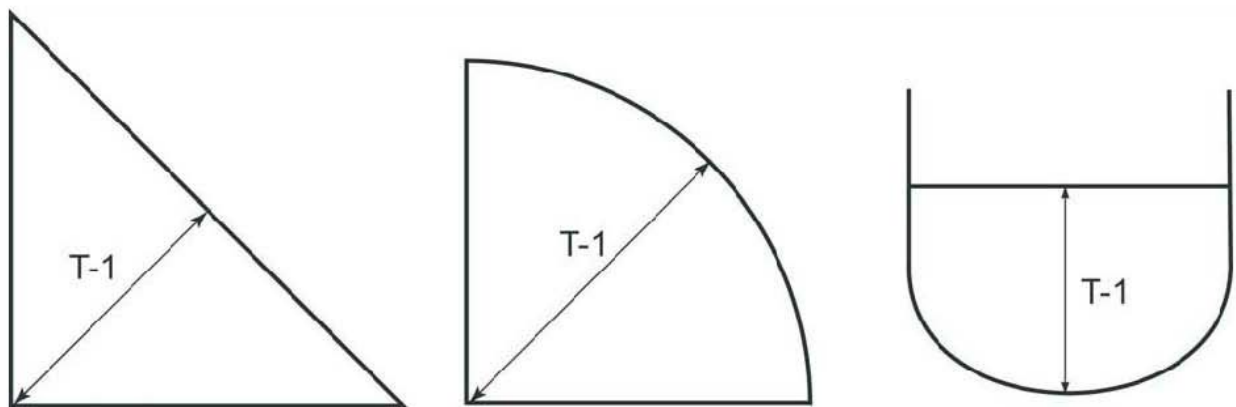
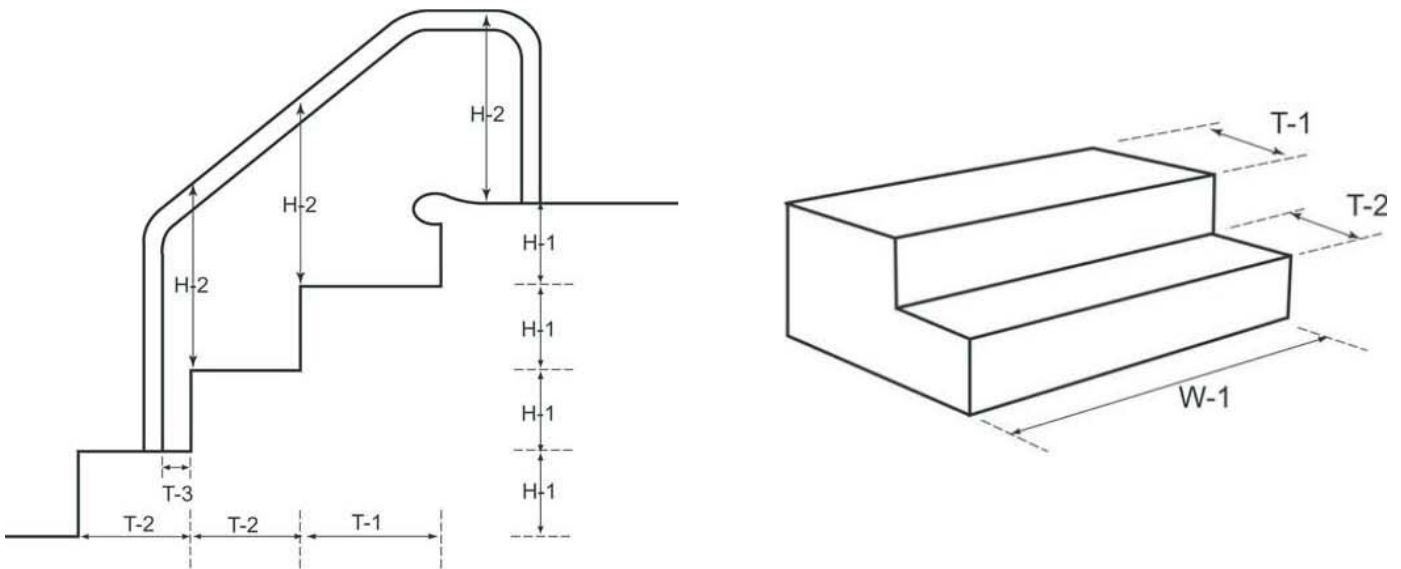

Dimensions	T-1 Standard	T-1 Triangular, Concave, Convex	T-2	T-3	W-1	H-1	H-2
Minimum	14"	21"	12"	3"	24"	6"	28"
Maximum	18"	24"	16"	---	---	12"	36"

Required Items for New Public Pool Plan Check Submission

For your use and to be verified when submitting plans

Included (Check)	Required Item	Comment
	Complete Application (for each pool) Plan submitter is a C-53 Contractor, A Contractor, Architect, or Engineer	
	Set of Drawings	
	Top View of Pool: -Minimum width 12' -Maximum surface area for a spa 250ft ² -Spa bench completely around	
	Profile View of Pool; Measurable slope to floor drains	
	Plot Plan	
	Pool Enclosure Details' -Highlighted Pool Enclosure Boundary -5' clear radius outside -5' set back from property line -No openable windows -Outside of enclosure is public area	
	Equipment room; Indicated location and indicated indoor or outdoor.	
	Deck Details Amenities (i.e. Fire pit, BBQ) have similar amenities outside of enclosure for non-pool users.	
	Restroom Details: Check facility type; a) Residential; if 300 ft or greater from pool wall to furthest unit, restrooms, showers, and drinking fountain(s) included. b) Non-residential; Included.	
	Solar Heating System Details if applicable	
	General Data and Equipment List	
	Other	