



# CHEMICAL HYGIENE PLAN

## and Laboratory Safety Manual

A Written Safety Program for Laboratories Utilizing Hazardous Chemicals

Publication Date January 2024

## Contents

<b>Chapter 1: Introduction</b> .....	<b>2</b>
Scope of this document .....	2
Rights and Responsibilities.....	3
Other UC Santa Barbara Safety Programs .....	8
<b>Chapter 2: Training and Outreach Programs</b> .....	<b>10</b>
On-Boarding Requirements for New Researchers.....	10
The Laboratory Safety Review Program .....	11
Incentive Programs and Targeted Trainings .....	12
<b>Chapter 3: Handling Hazardous Chemicals</b> .....	<b>14</b>
Chemical Hazard Classes.....	14
Chemical Hazard Communication.....	26
How to Reduce Exposures to Hazardous Chemicals (Hazard Controls).....	29
Good Laboratory Practices.....	41
Chemical Inventory, Storage, and Transport .....	44
Chemical Exposures: Limits, Assessments, and Medical Evaluations .....	54
Hazardous Chemical Waste Management.....	59
<b>Chapter 4: Emergencies</b> .....	<b>67</b>
Accidents.....	68
Laboratory Safety Equipment .....	69
Fire-Related Emergencies .....	71
Chemical Spills.....	71
Earthquake.....	74
<b>Chapter 5: Compliance</b> .....	<b>75</b>
Recordkeeping Requirements.....	75
Notification and Accountability .....	75
Compliance Procedures .....	75
<b>Acknowledgements</b> .....	<b>78</b>

# Chapter 1: Introduction

## Scope of this document

UC Santa Barbara is committed to providing a healthy and safe working environment for the campus community. In the case of laboratory personnel, a formal safety program is outlined in the form of the Chemical Hygiene Plan, as required by Cal/OSHA regulation [8 CCR §5191](#), also known as the ‘*Laboratory Standard*’. This document describes the training and controls in place to protect laboratory personnel against adverse health and safety hazards associated with exposure to potentially hazardous chemicals. This includes all proper use and handling practices and procedures to be followed by faculty, staff, students, visiting scholars, volunteers, and all other personnel working with potentially hazardous chemicals in a laboratory setting.

To be defined as a laboratory setting, the following criteria must be met:

- Chemical manipulations are on a scale that is easily and safely manipulated by one person (lab scale).
- Multiple chemical procedures are used.
- Procedures are not part of a production process, nor simulate a production process.
- Protective laboratory practices and equipment are available and commonly used.

The information presented in this document represents best practices and provides a broad overview of the information necessary for the safe operation of laboratories that utilize potentially hazardous chemicals. It is not intended to be all inclusive, nor should it be considered a complete Chemical Hygiene Plan. To be considered a complete Chemical Hygiene Plan, this document must be accompanied by a set of Standard Operating Procedures developed by researchers and approved by the Principal Investigator/Laboratory supervisor. [Templates](#) for the development of these SOP’s are available from Environmental Health and Safety.

The CHP does not apply to research involving *exclusively* radiological or biological materials, as these safety procedures and regulatory requirements are outlined separately in the [Radiation Safety Manual](#) and the [Biosafety Guide](#) respectively. Research that involves more than one type of hazard must comply with all applicable regulatory requirements and follow guidance outlined in the relevant safety manuals.

*Areas that are defined as laboratories by the university, but that use no chemicals or only a limited amount of specific low-hazard chemicals, may be exempt from the requirement to have a Chemical Hygiene Plan. Upon receiving this exemption, these laboratories will be required instead to comply with the [Injury and Illness Protection Program](#) or the [Hazard Communication Standard](#), respectively. Any PI/Laboratory Supervisor wishing to investigate this possibility should contact EH&S for a hazard assessment.*

## Rights and Responsibilities

# Rights



- Safe work environment
- Safety training
- Report safety concerns without fear of reprisal
- Exposure to chemicals, noise and heat only at safe levels

# Responsibilities



- Comply with applicable safety laws, regulations and UC policies.
- Attend any required safety training
- Correct or report uncontrolled hazards
- Obtain and use safety Information (SDS)

### **Responsibilities of All Personnel who handle Potentially Hazardous Chemicals**

All personnel in research or teaching laboratories that use or store potentially hazardous chemicals are responsible for:

1. Completing all required trainings and refreshers. Ensuring that this training has been documented on a [Training Needs Assessment form](#).
2. Reviewing, understanding and following the Chemical Hygiene Plan and all other appropriate Safety Manuals and Policies as determined by the hazards present in the laboratory.
3. Following all verbal and written rules, Standard Operating Procedures and policies established by the PI/Laboratory Supervisor.
4. Developing good personal chemical hygiene habits, including keeping the work area safe and uncluttered, ensuring that fume hoods are not used for storage, etc.
5. Immediately reporting unsafe acts, unsafe conditions and lab accidents to the PI/Laboratory Supervisor, and being prepared for laboratory accidents and emergencies (knowing emergency response procedures).
6. Assessing and controlling hazards associated with their experiments and work area prior to conducting work, including consistent and proper use of Engineering Controls (e.g. fume hoods),

Administrative Controls (e.g. SOP's), and Personal Protective Equipment (e.g. safety glasses and lab coats).

7. Following all UC Santa Barbara, state and federal requirements for the collection and disposal of hazardous waste.
8. When working autonomously or performing independent research work:
  - a. Reviewing the plan or scope of work for their proposed research with the PI/Laboratory Supervisor.
  - b. Notifying in writing and consulting with the PI/Laboratory Supervisor, in advance, if they intend to significantly deviate from previously reviewed procedures. Examples of significant changes include change in objectives, change in experimental conditions, change in required PPE, and reduction or elimination of administrative and/or engineering controls.
  - c. Preparing SOPs and hazard analyses and performing literature searches relevant to safety and health that are appropriate for their work, and
  - d. Providing appropriate oversight, training and safety information to personnel they supervise.
9. Disposing of, or transferring to new ownership, all research materials in advance of leaving their assigned laboratory space (e.g. leaving the research group, leaving UCSB, relocating to new space).

## **Responsibilities of the Principal Investigator/Laboratory Supervisor**

The Principle Investigator or person responsible for the laboratory space has the responsibility for the health and safety of all personnel working in his or her laboratory who handle hazardous chemicals. *The tasks and duties related to this may be delegated, but the responsibility for ensuring that these duties are adequately performed remains with the PI/Laboratory supervisor.* The PI/laboratory supervisor is responsible for:

1. Training all laboratory personnel to work safely with hazardous materials. This includes ensuring that they attend any mandatory trainings, review the hazard assessment, read and sign the group Chemical Hygiene Plan, and document this training on the [Training Needs Assessment form](#).
2. Completing a hazard assessment for their laboratory using the online [ASSESSMENT](#) tool as well as recertifying the assessment every three years, ensuring the lab roster is up to date and that all lab members have acknowledged the hazard assessment and completed PPE training. Completing all required Standard Operating Procedures as determined by the contents of their chemical inventory. Implementing the necessary controls as guided by this process. Ensuring that lab personnel notify the PI in writing in advance of deviating significantly from these published procedures and assessments. Examples of significant changes include change in

objectives, change in experimental conditions, change in required PPE, and reduction or elimination of administrative and/or engineering controls

3. Providing laboratory workers continuous access to the Chemical Hygiene Plan, either hard copy or electronic, and ensuring that the group-specific materials (contact information, standard operating procedures, etc.) are current and updated annually.
4. Knowing all applicable health and safety rules and regulations, training and reporting requirements associated with chemical safety for regulated substances ([Controlled Substances](#), [Regulated Carcinogens](#), [Select Agents \(toxins\)](#), [Homeland Security Chemical Facility Anti-Terrorism Standard chemicals of interest](#), etc.)
5. Monitoring the safety performance of laboratory workers and visitors, and enforcing policies and rules.
6. Promptly disposing of used, excess or unwanted hazardous chemicals following UC Santa Barbara, state and federal [waste disposal requirements](#).
7. Addressing any findings arising from the [Laboratory Safety Review](#) process in the time allotted for [the priority level of the finding](#).
8. Promptly reporting all accidents, injuries and fire extinguisher use to EH&S. For injuries, also completing all worker's compensation [reporting requirements](#).
9. Informing facilities personnel and outside contractors of potential workplace-related hazards when they are required to work in the laboratory space. This includes identifying and removing potential hazards to provide a safe environment for repairs and renovations.
10. Assigning one or more responsible persons the requirements listed above if the PI/Laboratory Supervisor will be on extended leave (> 2 weeks).

## **Responsibilities of Environmental Health and Safety**

EH&S is responsible for administering and overseeing institutional implementation of the Laboratory Safety Program. The Chemical Hygiene Officer (CHO) has primary responsibility for ensuring the implementation of all components of the CHP. The Fire Marshal is responsible for plan review, construction inspections, fire clearance, fire prevention inspections, testing and consultative services related to fire prevention. In case of life safety matters or immediate danger to life or health (IDLH), the Director of EH&S or designee has the authority to order immediate cessation of the activity until the hazardous condition is abated. EH&S provides technical guidance to personnel at all levels of responsibility on matters pertaining to laboratory use of hazardous materials.

The CHO is responsible for:

1. Informing PI/Laboratory Supervisors of all health and safety requirements and assisting with the selection of appropriate safety controls, including appropriate laboratory practices, personal protective equipment and engineering controls for the scope of work being conducted.
2. Managing the Laboratory Review Program. Consulting with the EH&S laboratory safety specialists on the results of their reviews, and necessary steps to abate hazards that may pose a risk to life or safety upon their discovery.
3. Assisting PI/Laboratory Supervisors with hazard assessments, upon request.
4. Assisting the PI/Laboratory Supervisors with the development of SOPs, upon request.
5. Helping to develop and implement appropriate chemical hygiene policies and practices.
6. Having working knowledge of current health and safety rules and regulations, training, reporting requirements, and standard operating procedures associated with regulated substances.
7. Providing technical guidance and investigation for laboratory accidents, injuries and near misses.
8. Reviewing and evaluating the effectiveness of the campus-wide portions of the CHP at least annually, and updating it as appropriate.
9. Providing consultation to the Chemical and Laboratory Safety Committee in the development and implementation of appropriate chemical hygiene policies and practices, and the development of SOPs and SOP templates.

**The Chemical Hygiene Officer for the departments of: Chemistry & Biochemistry, Materials, Chemical Engineering and Electrical and Computer Engineering is Nikolai Evdokimov ([nevdokimov@ucsb.edu](mailto:nevdokimov@ucsb.edu))**

**The Chemical Hygiene Officer for all other departments is Hector Acuna ([hector.acuna@ucsb.edu](mailto:hector.acuna@ucsb.edu)).**

The Fire Marshal is responsible for:

1. Ensuring that the campus complies with California statutes, and fire and life safety rules and regulations of the California State Fire Marshal as adopted or referenced in Title 19 and Title 24 (Parts 2m3m4m5 and 8) of the California Code of Regulations.
2. Inspecting campus facilities, processes and fire protection systems to ensure conformance with State statutes, rules, regulations, and UC fire safety policy.
3. Providing training in fire prevention and use of fire extinguishers.

**The Campus Fire Marshal is James White ([james.white@ucsb.edu](mailto:james.white@ucsb.edu)).**

## **Responsibilities of the Chemical and Physical Hazard Safety Committee**

The Chemical and Physical Hazards Safety Committee is empowered to promote a safe working environment with respect to chemical and physical hazards in all research and teaching laboratories on campus. It would advise and report to the Chancellor through the Vice Chancellor of Research. The physical hazards covered by this committee include all such hazards not covered by another safety committee, e.g. radioactive materials. These hazards include but are not limited to: electrical hazards, magnetic fields, lasers, extreme temperatures, pressure and vacuum, kinetic energy and noise.

The Chemical and Physical Hazard Safety Committee is responsible for:

*Immediate/Emergency functions:*

1. Convene with urgency upon the occurrence of an incident or near-miss in order to analyze the situation and advise on immediate actions necessary to mitigate the risk until long-term corrections are in place.
2. Execute formal escalation protocols to address cases of known but uncorrected noncompliance with Federal/State/local safety regulations as well as UC and UCSB safety related policies.

*Administrative functions*

1. To review, edit and approve annual updates to the campus Chemical Hygiene Plan (CHP) generated by the Research Safety Division of EH&S
2. Develop, recommend, update and maintain policies and procedures applicable to chemical and physical hazard safety. To enable this process, the committee will:
  - a. Receive and review summary reports from EH&S laboratory safety inspections, near miss reports and incident reports.
  - b. Review findings of inspectors from outside agencies including state and federal regulatory authorities.
  - c. Receive input from individual faculty and researchers.
3. Establish formal escalation protocols to address cases of known but uncorrected noncompliance with Federal/State/local safety regulations as well as UC and UCSB safety related policies.
4. Establish and review strategies to ensure adequate surveillance, hazard identification and risk assessment of laboratory activities related to chemical and physical hazards.
5. Design review of new and renovated laboratory space.

### **Responsibilities of Campus Administration**

The Chancellor and Vice Chancellors are responsible for the implementation of UC Santa Barbara's [Environmental Health and Safety Policy](#) on campus property. Deans, Directors, and Department Chairs are responsible for establishing and maintaining safety programs in their area to ensure they are providing a safe and healthy work environment.



## Other UC Santa Barbara Safety Programs

Given the breadth of research at UCSB, there are other campus safety programs and regulations that can apply to a given operation. Affected individuals should contact these program managers for further information:

**Injury and Illness Prevention Program:** The “umbrella” OSHA-required worker safety program that applies to all campus workers, regardless of work activities. There is significant overlap between IIPP elements and this manual as relates to lab work, particularly the training and inspection components.

**Biological Safety Program:** Biological Use Authorizations; Aerosol Transmittable Diseases; Blood borne Pathogens; Medical Waste Management

**Radiation Safety Program:** Oversight of radioactive materials; radiation-producing machines, magnets and lasers

**Chemical Hazard Communication Program:** Safety Data Sheets (formerly MSDS); chemical labeling (for labs, much of the HazCom program is superseded by the CHP program – see SDS pg. in Sec. II)

**Research Diving and Boating Safety Program:** Oversight of research projects involving SCUBA and small boats

**Field Research Safety:** Training and resources for research field work.

**Controlled Substance Program:** Oversight of research activities using State/Federal regulated narcotic and non-narcotic drugs

**Fire Protection Programs:** Includes fire extinguisher training for lab workers, oversight and inspections of fire alarms, sprinklers and other fire protection infrastructure, plus State Fire Marshal approval of plans for lab construction.

**Animal Care and Use:** Oversight of care and use of animals used in campus research activities

**Respiratory Protection Program:** Per Cal/OSHA regulations and UCSB Campus Policy, all UCSB personnel who use respiratory protection equipment including filtering facepiece respirators (dust masks) shall be included in the UCSB Respiratory Protection Program.

**Confined Space Program:** Campus/OSHA requirements and procedures for entering Permit Required Confined Spaces

**Indoor Air Quality Program:** Response to concerns regarding IAQ within and around campus buildings, especially as relates to health and comfort of building occupants

**Hearing Conservation Program:** Personnel exposed to occupational noise levels exceeding an 8-hr time-weighted average of 85 dBA must be enrolled in this UCSB/OSHA program

**Heat Illness Prevention Program:** Establishes campus/OSHA requirements and procedures for individuals who perform outdoor work

**Ergonomics Program**: Assessments and trainings designed to analyze and evaluate an employee's workspace, equipment, body mechanics, posture, and work flow to promote a more efficient, productive worker and prevent musculoskeletal injuries.

## Chapter 2: Training and Outreach Programs

### On-Boarding Requirements for New Researchers

Effective training is critical to facilitating a safe and healthy work environment and preventing laboratory accidents. All PI/Laboratory Supervisors must participate in formal safety training and ensure that all their employees have appropriate safety training before working in a laboratory, per [UC policy](#). At UC Santa Barbara, these new researcher training requirements are satisfied by completing the following:

#### **Fundamentals of Laboratory Safety**

This is the initial training course that is required before entry into the laboratory is allowed. It can be taken live or online. [Live classes](#) are offered in the fall for all incoming graduate students, and every two months year-round. The online class is accessed through the [UC Santa Barbara Learning Center](#). Instructions on how to activate your NetID and register for the class are found [here](#). This course covers the following:

- Review of laboratory rules and regulations, including the Chemical Hygiene Plan.
- Recognition of laboratory hazards.
- Types of engineering controls and personal protective equipment.
- Signs and symptoms associated with exposures to hazardous chemicals.
- Chemical exposure monitoring.
- Procedures for disposing of chemical waste.
- Fire safety and emergency procedures.

The primary difference in content between the live and online class is that the live class includes hands-on fire extinguisher training. Otherwise, the two classes are considered equivalent by EH&S. PI/Laboratory Supervisors and/or departments may however choose to require the live class over the online class. Whichever class is taken, there is an online refresher course required every three years. Those due for the refresher class will get an automated email from the Learning Center.

#### **Laboratory Specific Hazard Assessment Review (ASSESSMENT Online Tool)**

Identifying hazards in the workplace is the fundamental first step in developing the appropriate controls for a safe workplace. Conversely, it is impossible to protect oneself from risks in the workplace if the hazards present have not been fully identified and understood.

At UC Santa Barbara, the online tool for identifying hazards in the laboratory is called [ASSESSMENT](#). This tool allows the PI/Laboratory Supervisor to:

- Assign members to a lab group.
- Determine hazards that are present in the lab through a set of guided questions.
- Easily communicate laboratory hazards to group members.
- Identify the proper personal protective equipment (PPE) to be used.

It allows group members to:

- View potential hazards present in the laboratory.
- Receive a list of proper PPE to be used in their lab setting, and a voucher for obtaining the PPE for free.
- Receive training on that PPE.

The PPE distribution center at UC Santa Barbara is located in the Chemistry building storeroom/receiving area (building 557, room 1432). The full process for obtaining PPE is outlined [here](#).

### **Laboratory-Specific Safety Orientation**

All new researchers must receive a day-one laboratory safety orientation per UC policy. This orientation includes emergency procedures and location of emergency equipment, Injury and incident reporting procedures, engineering control use (fume hoods, etc.), a review of the Chemical Hygiene Plan and group specific SOP's, physical hazard training (e.g. cryogenics, high voltage, etc.) PPE use and waste disposal procedures. These lab-specific trainings should be conducted by the PI/Laboratory Supervisor or an experienced research group member who is familiar with the hazards present in the laboratory.

Additionally, any other training requirements should be assessed at this time. This includes use of radioactive materials, radiation producing machines, lasers, biological hazards, controlled substances, etc. These are [formal classes](#) that are conducted by EH&S staff.

All of the above training needs and documentation of receipt of that training must be kept on the [Training Needs Assessment](#) form. This form is in checklist format to assist the PI/Laboratory Supervisor in determining what trainings that individual needs. Generally, one form per researcher is generated and kept in the research group's files, although some shared facilities use modified but compliant approaches.

## The Laboratory Safety Review Program

Environmental Health and Safety visits each lab space at least once per year. The main program through which these visits are conducted is the [Laboratory Safety Review Program](#). This process consists of the following steps:

1. An EH&S staff member will reach out to each research group and schedule a meeting time with the PI/Laboratory Supervisor or a delegate.
2. The EH&S staff member and the PI/delegate will review various elements of the group's safety program: standard operating procedures, training records, walk-through of the physical space, etc.
3. A report will be sent to the PI/Laboratory Supervisor via [an email directing them to log into our online INSPECT tool](#).

4. A follow-up visit will then be scheduled so that EH&S can validate and assist with the resolution of any findings.

Laboratories with Biological and/or Radiological hazards will also receive independent targeted visits from the Biosafety Officer and/or the Radiation Safety Officer.

Additionally, it is strongly recommended that employers (PI's) conduct regular self-inspections of their workspaces. To assist with this, EH&S has developed this [Self-Inspection Checklist](#).

## Incentive Programs and Targeted Trainings

### **Incentive Program**

The Research Safety Incentive Program provides EH&S the opportunity to recognize the contribution of those laboratories or individuals that have improved the safety culture. This program has two facets, described below.

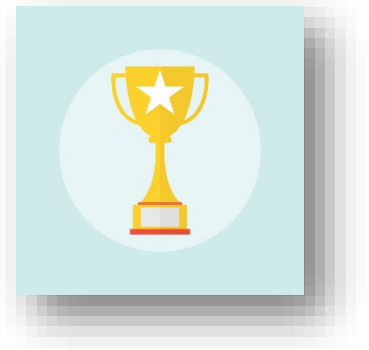

#### *On the Spot Safety Award*

We will recognize lab workers who are proactive in furthering and modeling behavior that is illustrative of a positive laboratory safety culture such as:

- Wearing proper protective equipment.
- Reporting a near miss that could have resulted in injury/illness.
- Recommending a meaningful, innovative improvement for a safer work area.

On-the-Spot Awards are presented to researchers by EH&S staff as the behavior is observed, and throughout the year. They consist of a small gift such as a gift card for a food or beverage establishment.

#### *Laboratory Safety Recognition*

We will recognize lab groups for their effort and devotion to safety. This includes those who display a strong safety culture as determined by Laboratory Safety Reviews as well as by regular informal interactions with EH&S staff.

EH&S will arrange a lunch or breakfast meeting with the lab group to recognize their efforts and allow for open discussion of any concerns, issues, or best practice ideas. We will also feature the lab group in the EHS newsletter: Safety Slick.

### **Targeted Training**

The goal of UC Santa Barbara is to achieve more than simple regulatory compliance. This campus strives toward fostering a strong, positive safety culture by integrating safety as an essential element in the daily work of laboratory researchers. EH&S's time and attention is therefore dedicated to providing assistance and guidance to lab groups on growing and optimizing their safety practices. We will provide hands on (refresher) trainings to those groups showing a need in a specific area. For example, if a lab group has continued issues of poor hazardous waste practices (e.g. open unattended containers, missing/incomplete waste label, etc.) we will arrange for a training in the lab. Additionally, EH&S is available to consult and meet with lab groups to discuss any relevant safety



topic/issue at the researchers' request. By meeting with lab groups and providing trainings as needed, EH&S hopes to foster a positive atmosphere for communication, education, advice, discussions, and the sharing of progress. Please feel free to contact your department's EH&S representative if you would like us to meet your group to discuss a safety topic or to provide a training:

**Andrea Tufekcic ([andreatufekcic@ucsb.edu](mailto:andreatufekcic@ucsb.edu))** for:

Chemistry & Biochemistry  
Earth Science  
Physics  
Electrical and Computer Engineering  
Molecular, Cell and Developmental Biology  
Materials Research Laboratory  
Neuroscience Research Institute

**Jose Diaz ([jose\\_diaz@ucsb.edu](mailto:jose_diaz@ucsb.edu))** for:

Anthropology  
Bren School  
Chemical Engineering  
CNSI  
Ecology, Evolution and Marine Biology  
Geography  
Materials  
Mechanical Engineering  
Natural Reserve System  
Psychology

Marine Science Institute labs contact **Cary Haack ([carlyhaack@ucsb.edu](mailto:carlyhaack@ucsb.edu))**.

## Chapter 3: Handling Hazardous Chemicals

### Chemical Hazard Classes

The [Globally Harmonized System](#) (GHS) of hazard communication was developed to identify to the user of a material both the hazards and the risks associated with it. This system recognizes thirty one classes of chemical hazards. These classes fall into three broad categories: physical hazards, health hazards, and environmental hazards. In addition, the severity of the hazard is assigned a numerical category of 1-4, with 1 being the most severe. These categories are rigorously defined for each hazard class in the OSHA publication [Hazard Communication: Hazard Classification Guidance for Manufacturers, Importers and Employers](#). A material may exhibit more than one hazard. A material's hazard class(es) determine how it is stored and handled, what special equipment may be needed, and what procedures need to be established to ensure safe handling. GHS information can be found on all commercial chemical labels printed after 2015, and the [Safety Data Sheet](#) (SDS) associated with that chemical. Any release of these materials to the environment must be reported to Environmental Health & Safety Immediately. Listed below are the hazard classes, along with the [associated GHS pictogram](#).

#### Reactive and Unstable Chemicals.

Reactive and unstable chemicals are those that may decompose violently, polymerize or self-react under conditions of shock, friction, temperature, pressure, light, or contact with other materials, resulting in the release of large volumes of gas or heat. Therefore, storage of these materials in such a way as to protect from these conditions is of the utmost importance. Additionally, they must be stored segregated from other materials in cabinets or refrigerator/freezer designed for storing flammable and reactive chemicals. *Examples: explosives, peroxides, azo and azido compounds.*

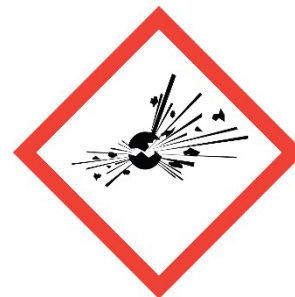

#### Oxidizers

Oxidizers are chemicals that cause or increase the intensity of the combustion of other materials. They can do so by delivering oxygen atoms, or by other means. Oxidizers should be stored in a cool, dry place and kept away from flammable and combustible materials such as organic chemicals, wood and plastic, and away from reducing agents. *Examples: Oxygen, Bromine, Nitric Acid, Hydrogen Peroxide.*



#### Flammable Chemicals

Flammable liquids include those chemicals that have a flashpoint of less than 100 °F. These materials must be stored in flammable storage cabinets, with no more than 10 gallons/room total outside of storage (including flammable organic waste). Flame-resistant laboratory coats must be worn when working with large volumes of flammable materials (>1L) and/or with procedures where a significant fire risk is present, such as working with an open flame or pyrophoric materials. These materials constitute a significant immediate threat and should be treated with particular care, given the comparatively large quantities that can be present in a laboratory setting. Particular attention should be given to preventing static electricity and sparks when handling flammable liquids. This can be accomplished in part by appropriately grounding metal flammable storage cabinets and any metal dispensing drums inside them, as well as the receiving container.



*Examples: Diethyl Ether, Acetone, Hexane*

**Pyrophoric Materials** are a class of materials that spontaneously ignite when in contact with air and require laboratory-specific training. Flame-resistant laboratory coats and hand protection must be worn when handling these chemicals. **Before working with pyrophoric materials, individuals must demonstrate knowledge of the appropriate methods to handle, transfer, and quench the material being used.** Templates for generating Standard Operating Procedures for pyrophoric materials handling can be found in the UC Santa Barbara [SOP Template Library](#).

*Examples: Grignard reagents, organolithium reagents, silane.*

**Water Reactive Chemicals** can evolve flammable or toxic gas when they come into contact with water or atmospheric moisture. Like pyrophoric materials, this reaction may produce enough heat to ignite any flammable gases thus generated. Therefore, they should be stored away from water and other sources of protons, such as acidic materials.

*Examples: potassium metal, sodium metal*

## Corrosives

As a health hazard, corrosive substances cause destruction of, or alterations in, living tissue by chemical action at the site of contact. Major classes of corrosive substances include:

- Strong acids: sulfuric, nitric, hydrochloric, etc.
- Strong bases: sodium hydroxide, potassium hydroxide, ammonium hydroxide.
- Dehydrating agents: phosphorus pentoxide, calcium oxide, etc.
- Oxidizing agents: hydrogen peroxide, chlorine, bromine, etc.



Symptoms of exposure via inhalation include a burning sensation, coughing, wheezing, laryngitis, shortness of breath, nausea and vomiting. For eye exposure, symptoms include pain, redness, tearing and blurring of vision. For exposure to the skin, symptoms may include pain, redness, inflammation, blistering and burns.



As a physical hazard, corrosive substances may degrade materials they come in contact with and may react violently. It is important to review information regarding the materials they may corrode, and their reactivity with other substances. They should be stored in chemically-compatible secondary containers, and should be segregated from other classes of materials.

### Irritants and Sensitizers

Irritants are non-corrosive chemicals that cause reversible inflammatory effects on living tissue by chemical action at the site of contact. A wide variety of organic and inorganic compounds, including many chemicals that are in a powder or crystalline form, are irritants. Consequently, eye and skin contact with all laboratory chemicals should be avoided. Symptoms of exposure can include reddening or discomfort of the skin and irritation to respiratory systems.

*Examples: Chlorine, methylene chloride, formaldehyde*



Sensitizers are chemicals which cause a substantial proportion of exposed people or animals to develop an allergic reaction after repeated exposure to the chemical. Symptoms can include all of the symptoms normally associated with allergic reaction, including life-threatening anaphylaxis.

*Examples: diazomethane, chromium, nickel, formaldehyde, isocyanates, many phenol derivatives.*

### Compressed Gases and Cryogenic Liquids

Compressed gas cylinders are pressurized vessels that pose both physical and health hazards additional to those of the gases they contain, and therefore must be handled and stored carefully. For example, even an inert, non-toxic gas like nitrogen poses an asphyxiation risk if the pressure in a nitrogen tank is released suddenly enough to overwhelm room ventilation. Additionally, a cylinder rupture (generally occurring at the weak spot in the cylinder located and the connection between the body of the cylinder and the valve) can lead to the cylinder becoming a projectile and endangering personnel, equipment and structures. Additionally, the gases themselves may have hazards associated with them such as flammability (hydrogen), toxicity (ammonia), reactivity (fluorine) and pyrophoricity (silane). **Highly toxic and pyrophoric gases are some of the most dangerous materials found in the laboratory. A gas-specific Standard Operating Procedure must be developed for these materials in conjunction with the campus Chemical Hygiene Officer.** *Examples of highly toxic gases: hydrogen fluoride, methyl bromide, nickel carbonyl, phosgene.*



All compressed gas cylinders must be stored with the safety cap in place when not in use. Cylinders must be held in place by a welded-link steel chain attached to mounts bolted into the structure, or chained in a cylinder storage rack. Specific gases may have additional storage requirements. Refer to the [‘Gases under pressure’ SOP template](#) for more information.

Cryogenic liquids such as liquid nitrogen and helium pose similar asphyxiation risks as their compressed gas counterparts. Additional hazards include frost burn of the skin and eyes. Always use appropriately insulated gloves when handling cryogenic liquids. Face shields may be needed, in addition to safety glasses/goggles, in cases where splashing may occur or when cryovials are being handled as they may explode when warmed. As cryogen dewars are at low pressure and have protective rings around the regulator, they do not need to be chained in storage.

### Particularly Hazardous Substances

Three classes of hazardous chemicals are defined by Cal/OSHA as '[Particularly Hazardous Substances](#)' (PHS). These classes are: *carcinogens*, *reproductive toxins*, and *acute toxins*. (It is important to note that many substances present in the laboratory are new chemical entities that have not been subjected to any kind of toxicity or carcinogenicity testing, and should be handled with that in mind.) Special provisions must be established and documented in laboratory SOPs to prevent the exposure of laboratory personnel to these materials, including:

- Establishment of designated areas
- Use of containment devices (e.g. fume hoods)
- Procedures for contaminated waste disposal
- Decontamination procedure.

These requirements will be discussed in the [Hazard Controls section](#).

### Carcinogens

Carcinogens are chemical or physical agents that cause cancer. Generally they exhibit chronic toxicity; that is, they cause damage after repeated or long-duration exposure, and their effects may only become evident after a long latency period. Chronic toxins of this kind are particularly insidious because they may have no immediately apparent harmful effects (also referred to as 'warning properties'). Carcinogenic chemicals are separated into three classes:

- Select Carcinogens
- Regulated Carcinogens
- Listed Carcinogens

*Select Carcinogens* are materials which have met certain criteria established by the National Toxicology Program (NTP) or the International Agency for Research on Cancer (IARC) regarding the risk of cancer via certain exposure routes. The following references are used to determine which substances are select carcinogens by Cal/OSHA's classification

- Is a Listed Carcinogen
- [Annual Report on Carcinogens](#) published by the National Toxicology Program (NTP), 'known to be carcinogens' and 'reasonably anticipated to be carcinogens' lists.



- [International Agency for Research on Cancer](#) (IARC), Group 1 ‘carcinogenic to humans, Group 2A ‘probably carcinogenic to humans, and Group 2B ‘possibly carcinogenic to humans’.
- Is a Regulated Carcinogen.

*Regulated Carcinogens* are of a higher hazard class than the select carcinogens, and therefore there are additional provisions required for their handling, per Cal/OSHA [8 CCR Article 110](#). This may include personal exposure monitoring. When working with regulated carcinogens, it is particularly important to review and effectively apply the Standard Operating Procedure for PHS’s. If it is found that a laboratory has exceeded the Cal/OSHA defined permissible exposure limit (PEL) for a regulated carcinogen, extensive additional regulatory requirements will apply to that laboratory. The regulated carcinogens are:

- |   |   |
|---|---|
| • Acrylonitrile                           | • Coke oven emissions                         |
| • Arsenic and inorganic arsenic compounds | • 1,2-Dibromo-3-chloropropane (DBCP)          |
| • Asbestos                                | • Ethylene dibromide (EDB)                    |
| • Benzene                                 | • Ethylene oxide (EtO)                        |
| • 1,3-Butadiene                           | • Formaldehyde gas and solutions              |
| • Cadmium metal and cadmium compounds     | • Lead and inorganic lead compounds           |
| • Chromium(VI) compounds                  | • Dichloromethane                             |
| • Methylenedianiline (MDA)                | • 4,4’-Methylene-bis(2-chloroaniline) (MBOCA) |
| • Vinyl chloride                          | • All Listed Carcinogens                      |

*Listed Carcinogens* are the thirteen chemicals listed in [8 CCR §5209](#). These chemicals are considered to pose the highest carcinogenicity hazard. They have many additional requirement for use beyond those required for regulated carcinogens. Given these strict regulatory requirements for use, handling and storage, the campus Chemical Hygiene Officer must be contacted before any work is initiated. Purchases of these materials will also be routed to the Chemical Hygiene Officer for approval. The Listed Carcinogens are:

- |  |                                      |
|--|--------------------------------------|
| • 2-acetylaminofluorine                | • 4-Nitrobiphenyl                    |
| • 4-Aminodiphenyl                      | • N-Nitrosodimethylamine             |
| • Benzidine and its salts              | • Beta-Propiolactone                 |
| • 3,3’-Dichlorobenzidine and its salts | • Bis-chloremethyl ether             |
| • 4-Dimethylaminobenzene               | • Methyl chloromethyl ether (MOM-Cl) |
| • Alpha-naphthylamine                  | • Ethyleneimine                      |
| • Beta-naphthylamine                   |                                      |

*Reproductive Toxins*

Reproductive toxins include any chemical that may affect reproductive capabilities, including causing chromosomal damage (mutagenesis), effects on fetuses (teratogenesis), and adverse effects on sexual function and fertility. Reproductive toxins can affect the reproductive health of both men and women if proper procedures and controls are not used. For women, exposure to reproductive toxins during pregnancy can cause adverse effects on the fetus; these effects include embryo lethality (death of the fertilized egg, embryo or fetus), malformations (teratogenic effects) and postnatal defects. For men, exposure can lead to sterility.



Examples of embryotoxins include thalidomide and certain antibiotics such as tetracycline. Women of childbearing potential should note that embryotoxins have the greatest impact during the first trimester of pregnancy. Because a woman often does not know that she is pregnant during this period of high susceptibility, special caution is advised when working with all chemicals, especially those rapidly absorbed through the skin (e.g. formamide). Pregnant women and women intending to become pregnant should consult with their laboratory supervisor and their physician before working with substances that are suspected to be reproductive toxins.

Mutagens are a class of materials that cause a change in the genetic material of a living cell. As such, they effect changes that can potentially lead to both reproductive toxicity and the development of cancer.

#### *Acute Toxins*

Acute toxins are substances that may be fatal as a result of a single exposure, or exposures of short duration, via one or more of three routes, defined as:

- ORAL: A chemical with a median lethal dose (LD<sub>50</sub>) of 50 mg or less per kg of body weight.
- DERMAL: A chemical with a median lethal dose (LD<sub>50</sub>) of 200 mg or less per kg of body weight.
- INHALED: A chemical that has a median lethal concentration (LC<sub>50</sub>) in air of 500 ppm by volume or less of gas, 2.0 mg per liter or less of vapor, or 0.5 mg per liter or less of mist or dust, when administered by continuous inhalation for 4 hours (or less if death occurs within 4 hours)



Substances or mixtures classified by their manufacturer under GHS as Category 1 or 2 for acute toxicity meet this definition, and the associated hazard statement specifies that they are “fatal” via one or more of the three exposure routes.

### Chemicals Known to the State of California to Cause Cancer or Reproductive Toxicity

The Safe Drinking Water and Toxic Enforcement Act of 1986, also known as [Proposition 65](#), requires the state to publish a list of chemicals known to cause cancer or reproductive toxicity. It also requires businesses to provide warnings to Californians about significant exposure to the chemicals on the list. These chemicals can be in the products that Californians purchase, in their homes or workplaces, or that are released into the environment. The University of California, as a government agency, is exempt from the warning requirements of this law.

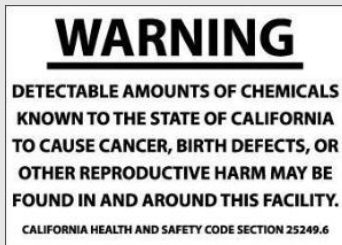

### Toxic Substances

Substances which may cause toxicity as the result of a single exposure, but are typically not fatal in small doses, are considered toxic. Substances classified as Category 3, 4 and 5 under GHS for acute toxicity meet this definition, *and are not considered particularly hazardous substances (PHS)*. Category 3 substances are associated with the skull-and-crossbones pictogram. Category 4 and 5 are associated with the exclamation mark pictogram.

Substances which cause damage to target organs are also considered to be toxic, and are indicated under GHS by the same health hazard pictogram as are carcinogens and reproductive toxins. These include:

- Hepatotoxins: Substances that damage the liver. *Examples: nitrosamines, carbon tetrachloride.*
- Nephrotoxins: Substances that damage the kidneys. *Examples: certain halogenated hydrocarbons, ethylene glycol (antifreeze).*
- Neurotoxins: Substances that damage the nervous system. *Examples: mercury, acrylamide, carbon disulfide.*
- Hematopoetic agents: Substances that decrease hemoglobin function and deprive the body tissues of oxygen. *Examples: carbon monoxide, cyanide ion.*
- Respiratory toxins: Substances that damage the lung tissue. *Examples: asbestos, silica.*



*Symptoms of exposure to toxic and acutely toxic materials vary. Those working with these materials should review the SDS for the specific material being used, and should take special note of the symptoms of exposure.*

### **Chemicals Hazardous to the Environment**

Materials with demonstrated toxicity to aquatic organisms are classified as toxic to the environment. It is particularly important that such materials be stored in a manner which minimizes the risk of accidental release, and that they be disposed of as hazardous waste. As with all hazardous chemicals, any release to the environment must be reported to Environmental Health and Safety immediately.

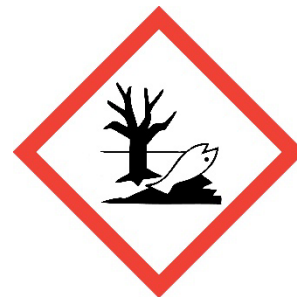

### **Peroxide-Forming Chemicals**

Materials that may form potentially explosive peroxides are not classified under GHS, but are of significant concern. These peroxides are much more shock-sensitive than TNT, and are also sensitive to sparks or other accidental ignition. Many of these chemicals are common organic solvents and care must be taken in their use and storage. There are no specific regulations that address the handling, classification of, or control methods for peroxidizable materials. The information included here is considered best practice and is based on [Prudent Practices in the Laboratory](#), Chapters 4 and 6.

Some moieties that are known to form peroxides include:

- Primary and secondary alkyl ethers
- Compounds with benzylic hydrogens
- Compounds with allylic hydrogens
- Compounds with a tertiary C-H group
- Conjugated polyunsaturated alkenes and alkynes
- Compounds containing secondary or tertiary C-H groups adjacent to an amide.



All peroxide-forming chemicals should be stored in airtight containers in a cool, dry area. If the container is transparent it should also be protected from light. Inventories should be carefully controlled, with the date of receipt and the date of opening marked on the label. There are three classes of peroxidizable chemicals, each with its own set of storage requirements. The three tables below are not comprehensive lists of each class, but are examples of each more commonly found in the laboratory.

*Class A: Chemicals that form explosive levels of peroxides without concentration.*

These chemicals form peroxides upon exposure to air, and continue to build peroxides to potentially dangerous levels. ***They are especially dangerous and must be discarded within 3 months of receipt or formation.***

**Class A Peroxide-Forming Chemicals:**

Isopropyl Ether	Sodium Amide
Butadiene liquid	Tetrafluoroethylene
Chlorobutadiene (chloroprene)	Divinyl Acetylene
Potassium Amide	Vinylidene Chloride
Potassium Metal	

*Class B: Chemicals that are a peroxide hazard on concentration.*

These chemicals form peroxides upon exposure to air, but develop a low equilibrium concentration. These chemicals become dangerous only when condensed via evaporation or distillation. The peroxide becomes concentrated because it is less volatile than the parent chemical. Note that with low boiling-point solvents such as diethyl ether, this concentration can occur while in storage. Thus, old bottles of peroxidizable low-boiling solvents can become dangerously shock-sensitive without any active effort to condense the liquid. Some of these materials are sold with inhibitors added to them, which does increase their shelf-life. However, users must be aware that distillations, condensations and other purification techniques will remove these stabilizers.

From the date of opening, ***Class B chemicals with inhibitors can be stored for 12 months, without inhibitors they can be stored for 6 months.*** After this point, they should be discarded. All Class B chemicals past the manufacturer’s expiration date should be discarded.

**Class B Peroxide-Forming Chemicals**

Acetal	<b>Dioxane</b>
Cumene	Ethylene Glycol Dimethyl Ether (Glyme)
Cyclohexene	Furan
Cyclooctene	Methyl Acetylene
Cyclopentene	Methyl Cyclopentane
Diacetylene	Methyl Isobutyl Ketone
Dicyclopentadiene	<b>Tetrahydrofuran</b>
Diethylene Glycol Dimethyl Ether (diglyme)	Tetrahydronaphthalene
<b>Diethyl ether</b>	Vinyl ethers

Common laboratory solvents in bold

*Class C: Unsaturated monomers that may autopolymerize as a result of peroxide accumulation*

This class of compounds consists of inhibitor free monomers designed to undergo free-radical polymerization. Upon exposure to air, these compounds can form peroxides that then violently polymerize. Often they are sold with a polymerization inhibitor added. These inhibitors require the presence of oxygen to function, and therefore these products should not be stored under an inert atmosphere. As this can cause confusion, please refer to the manufacturer instructions and/or the SDS

for storage requirements. **Pure, uninhibited materials must only be stored for 5 days or less. Inhibited material may be stored for 12 months.**

### Class C Peroxide-Forming Chemicals

Acrylic Acid	Styrene
Butadiene gas	Vinyl Acetate
Chlorotrifluoroethylene	Vinyl Chloride
Ethyl Acrylate	Vinyl Pyridine
Methyl Methacrylate	

If you find a container of peroxidizable material of unknown age or origin, isolate the immediate area and call EH&S at **(805) 893-3194**.

### Nanomaterials

The increasing use of nanomaterials in research labs warrants consideration of the hazards they may pose. As is the case with many new technologies, the health effects of nanomaterials have not been thoroughly investigated. Consequently, the uncertainty surrounding the health hazards of nanomaterials merits a cautious approach when working with them.

*Nanomaterials include any materials or particles that have an external dimension in the nanoscale (1-100 nm).* Nanomaterials are both naturally occurring in the environment and intentionally produced.

Intentionally produced nanomaterials are referred to as Engineered Nanomaterials (ENM). Materials whose properties do not differ significantly between their nanoscale and larger forms are generally excluded from ENMs. Some examples of ENMs include fullerenes, carbon nanotubes, carbon nanofibers, quantum dots and metal oxide nanoparticles.

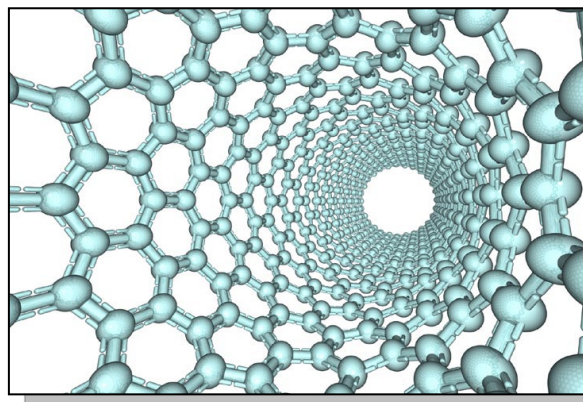

The parent compound of the nanomaterial should also be taken into consideration when evaluating the potential hazards associated with exposure (e.g. a highly toxic compound such as cadmium should be anticipated to be at least as toxic and possibly more toxic when used as a nanomaterial). However, even materials which are non-toxic in their bulk phase (e.g. carbon) may display significant toxicity as nanomaterials (e.g. multiwall carbon nanotubes).

Naturally occurring nanomaterials like amorphous silica and carbon black have legal (Cal/OSHA) exposure limits (for these examples 80 mg/m<sup>3</sup> and 3.5 mg/m<sup>3</sup> respectively). Currently, there are no legal exposure limits for engineered nanomaterials in the US or internationally. However, NIOSH (National Institute for Occupational Safety and Health) has developed Recommended Exposure Limits (RELs) for just two ENMs: carbon nanotubes (7 µg/m<sup>3</sup>) and nano-titanium dioxide (0.3 µg/m<sup>3</sup>).



Nanomaterials are categorized by the potential risk of exposure they pose to personnel based on the physical state of the materials and the conditions in which they are used. In general, the risk of exposure is lowest when nanomaterials are bound in a solid matrix with little potential to create airborne dust, or when in a non-volatile liquid suspension. The risk of exposure increases when nanomaterials are used as fine powders, are suspended in volatile solvents or gases, or are used in procedures capable of producing aerosols. The [Nanotoolkit](#) referenced below divides these materials into 3 categories, and assigns appropriate controls to each (Table 3.1). This allows researchers to develop a Standard Operating Procedure (SOP) for handling their ENM given these factors. In moderate to high exposure risk cases as determined by the Nanotoolkit, it is advisable to reach out to the [EH&S Respiratory Protection Program](#) for a consultation, as respiratory protection may be required. Personal Protective Equipment such as gloves should be chosen taking into consideration the nanomaterial as well as other chemicals being used in conjunction with them, such as solvents. Double gloving is advised.

**Table 3.1**

Risk level	Controls	
<b>Category 1</b> Low Exposure Potential	Engineering	<ul style="list-style-type: none"> <li>• <b>Fume Hood or Biosafety Cabinet.</b> Perform work with open containers of nanomaterials in liquid suspension or gels in a laboratory-type fume hood or biosafety cabinet, as practical.</li> </ul>
	Work Practices	<ul style="list-style-type: none"> <li>• <b>Storage and labeling.</b> Store in sealed container and secondary containment with other compatible chemicals. Label chemical container with identity of content (include the term "nano" in descriptor).</li> <li>• <b>Preparation.</b> Line workspace with absorbent materials.</li> <li>• <b>Transfer in secondary containment.</b> Transfer between laboratories or buildings in sealed containers with secondary containment.</li> <li>• <b>Housekeeping.</b> Clean all surfaces potentially contaminated with nanoparticles (i.e., benches, glassware, apparatus) at the end of each operation using a HEPA vacuum and/or wet wiping methods. DO NOT dry sweep or use compressed air.</li> <li>• <b>Hygiene.</b> Wash hands frequently. Upon leaving the work area, remove any PPE and wash hands, forearms, face, and neck.</li> <li>• <b>Notification.</b> Follow institution's hazard communication processes for advanced notification of animal facility and cage labeling/management requirements if dosing animals with the nanomaterial</li> </ul>
	PPE	<ul style="list-style-type: none"> <li>• <b>Eye protection.</b> Wear proper safety glasses with side shields (for powders or liquids with low probability for dispersion into the air)</li> <li>• <b>Face protection.</b> Use face shield where splash potential exists.</li> <li>• <b>Gloves.</b> Wear disposable gloves to match the hazard, including consideration of other chemicals used in conjunction with nanomaterials (refer to Table 1, Glove Choices for Nanomaterials)</li> <li>• <b>Body protection.</b> Wear laboratory coat and long pants (no cuffs).</li> <li>• <b>Closed toe shoes.</b></li> </ul>
<b>Category 2</b> Moderate Exposure Potential	Engineering	<ul style="list-style-type: none"> <li>• <b>Fume Hood, Biosafety Cabinet, or Enclosed System.</b> Perform work in a laboratory-type fume hood, biosafety cabinet* (must be ducted if used in conjunction with volatile compounds), powder handling enclosure, or enclosed system (i.e., glove box, glove bag, or sealed chamber).</li> </ul>
	Work Practices	<ul style="list-style-type: none"> <li>• <b>Category 1 Work Practices.</b> Follow all work practices listed for Category 1.</li> <li>• <b>Access.</b> Restrict access.</li> <li>• <b>Signage.</b> Post signs in area.</li> <li>• <b>Materials.</b> Use antistatic paper and/or sticky mats with powders.</li> </ul>
	PPE	<ul style="list-style-type: none"> <li>• <b>Category 1 PPE.</b> Wear all PPE listed for Category 1.</li> <li>• <b>Eye protection.</b> Wear proper chemical splash goggles (for liquids with powders with moderate to high probability for dispersion into the air).</li> <li>• <b>Gloves.</b> Wear two layers of disposable, chemical-protective gloves.</li> <li>• <b>Body protection.</b> Wear laboratory coat made of non-woven fabrics with elastic at the wrists (disposable Tyvek®-type coveralls preferred).</li> <li>• <b>Closed toe shoes.</b> Wear disposable over-the-shoe booties to prevent tracking nanomaterials from the laboratory when working with powders and pellets.</li> <li>• <b>Respiratory Protection.</b> If working with engineering controls is not feasible, respiratory protection may be required. Consult an EH&amp;S professional for more information (i.e., N95 respirator, or one fitted with a P-100 cartridge).</li> </ul>
<b>Category 3</b> High Exposure Potential	Engineering	<ul style="list-style-type: none"> <li>• <b>Enclosed System.</b> Perform work in an enclosed system (i.e., glove box, glove bag, or sealed chamber).</li> </ul>
	Work Practices	<ul style="list-style-type: none"> <li>• <b>Category 2 Work Practices.</b> Follow all work practices listed for Category 2.</li> </ul>
	PPE	<ul style="list-style-type: none"> <li>• <b>Category 2 PPE.</b> Wear all PPE listed for Category 2.</li> <li>• <b>Body protection.</b> Wear disposable Tyvek®-type coveralls with head coverage.</li> <li>• <b>Respiratory Protection.</b> If working with engineering controls is not feasible, respiratory protection may be required. Consult an EH&amp;S professional for more information (i.e., N95 respirator, or one fitted with a P-100 cartridge).</li> </ul>

For more information, see:

- The California Nanosafety Consortium of Higher Education’s [Nanotoolkit: Working Safety with Engineered Nanomaterials in Academic Research Settings](#),
- The National Institute of Occupational Safety & Health’s (NIOSH) [General Safe Practices for Working with Engineered Nanomaterials in Research Laboratories](#), and
- The National Institute of Occupational Safety & Health’s (NIOSH) [Current Strategies for Engineering Controls in Nanomaterial Production and Downstream Handling Processes](#).

### **Determining Hazard Classes**

For materials obtained from outside suppliers, PIs/Laboratory Supervisors may rely on the hazard determination of the manufacturer. However, PIs/Laboratory Supervisors are responsible for making reasonable determinations of the health and/or physical hazards of any *materials produced in their laboratories*.

The term ‘hazardous substance’ refers to any chemical for which there is statistically significant evidence based on at least one study conducted in accordance with established scientific principles that acute or chronic health effects may occur in exposed individuals. PIs/Laboratory Supervisors may assume that any chemical of known composition produced in their lab is hazardous if it is listed in the following:

- Cal/OSHA’s The Hazardous Substance List: [8 CCR §339](#), commonly referred to as the Director’s List of Hazardous Substances.
- Cal/OSHA’s Toxic and hazardous Substances, Air Contaminants: [8 CCR §5155](#).
- [Threshold Limit Values for Chemical Substances in the Work Environment](#), ACGIH, 2009.
- [Fourteenth Annual Report on Carcinogens](#), NTP, 2016
- [Monographs](#), IARC, WHO
- Chemicals Known to the State to Cause Cancer or Reproductive Toxicity: [Proposition 65, 22 CCR §12000](#),

Any chemical of unknown composition should be presumed to be hazardous. Chemical derivatives of known materials should be presumed to be at least as hazardous as their parent compound. In all such cases, PIs/Laboratory Supervisors should take appropriate steps to prevent exposure.

## Chemical Hazard Communication

Employers are required by Cal/OSHA to provide information to their employees about the hazardous substances to which they may be exposed. Below are the main routes by which this information is disseminated.

### Chemical Labeling

All chemicals in the laboratory should be properly labeled. Commercial chemicals come with a manufacturer's label which contains the necessary information. Care should be taken not to remove or deface these labels. For containers without manufacturer's labels, the following labeling requirements must be adhered to:

- All containers of hazardous materials must be labeled with the identity of the substance, legibly and in English. Acronyms (e.g. IPA) and chemical formulas alone do not fulfill this requirement.
- The label must contain applicable warning statements (e.g. Flammable, corrosive).
- Particularly Hazardous Substances (PHS) must also be labeled with the specific hazard that meets the definition of PHS (e.g. Acute Toxin, Carcinogen, Reproductive Toxin). Additionally, *the storage area where PHS's are kept must also be labeled with the type of hazard*. These chemicals should be segregated from other chemicals to help with proper access control and hazard identification.
- Peroxide forming chemicals must be labeled with the *date of receipt and the date of opening*.

### Safety Data Sheets (SDS)

An SDS must be available for each hazardous substance in a laboratory's chemical inventory. PI's/laboratory Supervisors are responsible for ensuring that all researchers have immediate access to SDS's, and are trained on how to access them, as well as understanding their relevance to the health and safety of the workplace. (SDS format and access requirements are covered in the mandatory EH&S Fundamentals of Laboratory Safety class.) Access may be either physical or digital.

Like the hazard class pictograms, SDS format and content have been standardized by the Globally Harmonized System. Chemical manufacturers are required to provide updated SDS's. The required 16 sections of an SDS are:

1. Identification of the substance or mixture, and of the supplier
2. Hazard Identification



3. Composition/information on ingredients.
4. First Aid measures
5. Firefighting measures
6. Accidental release measures
7. Handling and storage
8. Exposure control/personal protection
9. Physical and chemical properties
10. Stability and reactivity
11. Toxicological information
12. Ecological information
13. Disposal considerations
14. Transport information
15. Regulatory information
16. Other information, including information on preparation and revision of the SDS



Some useful links for accessing SDS's on line are located on the [EH&S website](#).

Figure 3.1

<b>EMERGENCY RESPONSE INFORMATION</b>			
Biological Sciences II	571	5106	Neuroscience Research
(Building Name)	(Bldg#)	(Room #)	(Department)
<b>Fire, Police or Medical Emergencies Call 911</b>			
<b>Hazardous Materials Incident</b> (Chemical, Radiation, Biological spills, odors, etc.) for assistance call Environmental Health & Safety 24 Hour line: <b>893-3194</b>			
Name	Campus Phone	After Hours Phone	Position
<b>Physical Hazards:</b> Inert Compressed gas UV Light	<b>Biological Materials:</b> Human Tissue Samples: Blood, Saliva, Urine, Feces	<b>Chemical Hazards:</b> Lab-sized Chemical Containers: Flammable liquids Corrosives	
<b>Continuously operating, unattended process</b> None			
 BIOHAZARD	 UV LIGHT	 Total volume: Less than 5 gallons	 Total volume: Less than 5 gallons
 Smoking Prohibited	 No eating or drinking in Chemical work areas	The designated work area for carcinogens, reproductive toxins & acute toxins is the entire lab. See the lab's Chemical Hygiene Plan.	
Total volume: Less than 5 gallons		 OXYGENS HAZARD	 Wash Hands before leaving
Contact x0243 or Email: <a href="mailto:hector.acuna@ehs.ucsb.edu">hector.acuna@ehs.ucsb.edu</a> to make changes to this sign. 1/18/2017			

## Door Placards

To aid emergency responders, every corridor entrance to laboratories has a placard conveying information regarding the types of hazards within and laboratory emergency contacts (Figure 3.1). The information is updated annually, but laboratories should submit a new [EH&S door placard form](#) if the placard becomes out of date at any time.

## Lab Hazard Assessment Tool (ASSESSMENT)

As described in the [previous chapter, ASSESSMENT](#), the new laboratory hazard assessment tool, was developed as a method for identifying and communicating the hazards that are present in each laboratory via a set of guided questions (**Figure 3.2**). As such, it is a key component to the hazard communication process for reducing workplace illness and injury

**Figure 3.2**

The screenshot displays the Lab Hazard Assessment Tool interface. On the left is a dark sidebar menu with the following items: HOME (with a home icon), LAB HAZARD ASSESSMENT, General (with a green checkmark), Roster (with a green checkmark), Locations (with a green checkmark), Assessment (with a green checkmark and highlighted in dark grey), Summary (with a green checkmark), and Next Steps. The main content area has a light grey header with five categories, each with a green checkmark: CHEMICAL HAZARDS, PHYSICAL HAZARDS, BIOLOGICAL HAZARDS, RADIOLOGICAL HAZARDS, and LASER HAZARD. Below the header, there are six assessment questions, each with a radio button for 'Yes' (selected) and 'No', and an information icon (i):

- C2. Working with hazardous liquids or other materials which create a splash hazard (i)
- C3. Working with small volumes ( $\leq 4$ L) of corrosive liquids or solids (i)
- C4. Working with large volumes ( $> 4$ L) of corrosive liquids or solids (i)
- C5. Working with small volumes ( $\leq 1$ L) of flammable solvents/materials when no reasonable ignition sources are present (i)
- C6. Working with large volumes ( $> 1$ L) of flammable solvents/materials (i)

## How to Reduce Exposures to Hazardous Chemicals (Hazard Controls)

There are four primary routes of exposure for chemicals that have associated health hazards (Figure 3.3):

1. Inhalation: e.g. breathing in chemical fumes
2. Ingestion: e.g. eating contaminated food in the lab
3. Absorption (through skin or eyes): e.g. chemical splash
4. Injection: e.g. contaminated needle stick or uptake through an existing wound

Of these, the most likely route of exposure in the laboratory is by inhalation. Many hazardous chemicals may affect people through more than one of these exposure routes, so it is critical that protective measures are in place for each of the uptake mechanisms.

The methodologies for controlling exposures to hazardous chemicals are termed 'Controls'. Each type of control is designed to reduce the *risk* of interacting with a material and its inherent *hazards*. It requires a carefully considered, multi-tiered system of safety controls to effectively manage the risks associated with exposure to these chemicals. Broadly, safety controls can be divided into four classifications: Elimination, Substitution, Engineering Controls, Administrative Controls, and Personal Protective Equipment.

In figure 3.4, each of these control types are ordered according to their effectiveness. Elements of all of these are used in a layered approach to create a safe working environment. The principles of each of these control types are detailed below.

### Figure 3.4: The Hierarchy of Controls

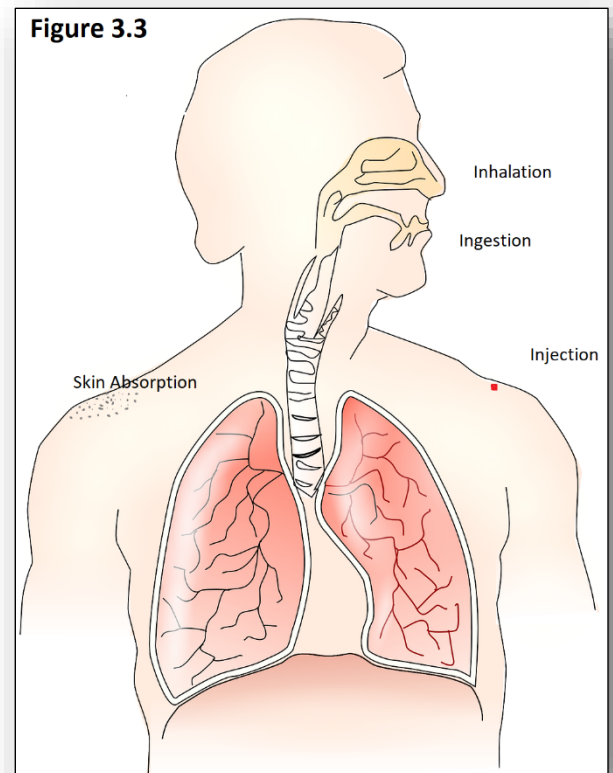

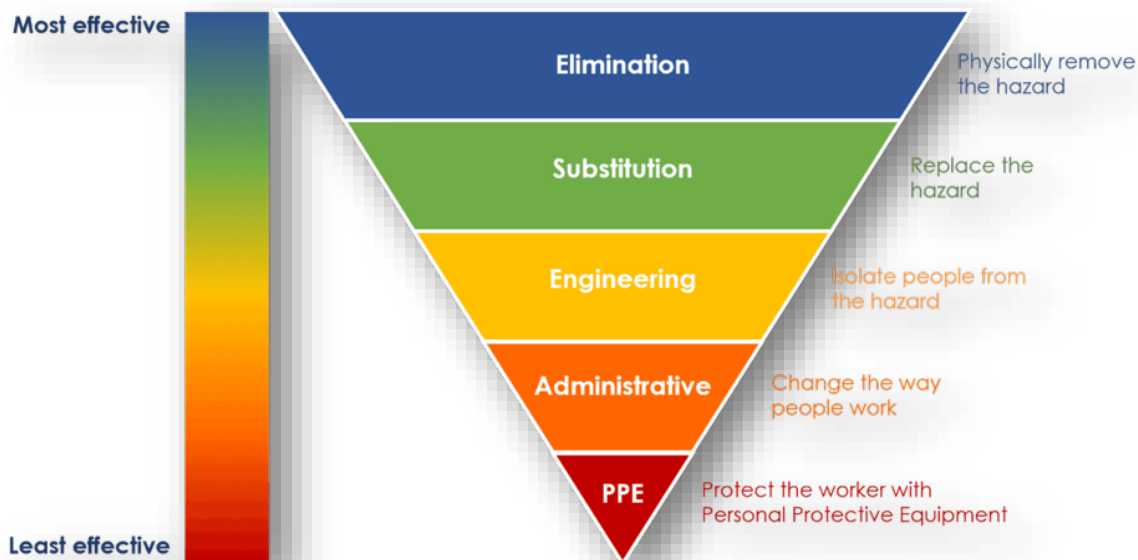

### Elimination and Substitution

The only way to reduce to zero the risk of interacting with a particular hazard is to remove that hazard completely. Thus, elimination is considered to be the most effective safety control. As this is often not practical in the laboratory, the next-best approach is to substitute the hazard with something less hazardous. Examples of substitution might include substituting toluene for benzene as a reaction or purification medium.

### Engineering Controls

The National Institute of Occupational Safety and Health ([NIOSH](#)) states that:

“Engineering Controls are used to remove a hazard or place a barrier between the worker and the hazard... Well-designed engineering controls can be highly effective in protecting workers and will typically be independent of worker interactions to provide this high level of protection.”

Following Elimination and Substitution these controls offer the first line of protection to prevent exposures to hazardous chemicals. As noted in the excerpt above, they require minimal alteration of procedures on the part of the researcher (except in emergency situations) and therefore are less prone to user error than other control methods. A fundamental and very common example is the laboratory fume hood, which is very effective at containing chemical fumes and vapors, and thereby protecting users from inhalation hazards. Other examples of engineering controls include flammable material storage cabinets, snorkels, and general room ventilation.

### General Laboratory Ventilation

Per California Fire Code and the [University of California Lab Safety Design Manual](#), laboratory spaces where hazardous materials are used or stored have mechanically generated and conditioned supply and exhaust air. The intakes supply outside fresh air, and the exhausts vent 100% to the outside, with no return of fume hood and laboratory general exhaust back into the building. The total volume of exhaust air should meet a minimum of 1 cfm/ft<sup>2</sup>, or roughly 6 air changes per hour. Laboratories are kept at negative pressure to adjoining non-laboratory spaces (e.g. the hallway) to prevent the spread of airborne hazards.

### Fume Hoods

Chemical fume hoods are the most commonly used local exhaust system on campus, and are one of the most important pieces of equipment used to protect workers from exposure to hazardous chemicals. Other examples of local exhaust systems include vented enclosures for large pieces of equipment or chemical storage, and movable exhaust systems for capturing contaminants near the point of release, a.k.a. snorkels. Figure 3.5 shows the key components of a fume hood.

There are two categories of chemical fume hood on campus: Constant Air Volume (CAV) and Variable Air Volume (VAV). As the name suggests, Constant Air volume (CAV) hoods always remove the same volume of air per unit time from the room, regardless of sash height. These hoods are calibrated such that the Cal/OSHA required working airflow rate of at least 100 linear feet per minute (fpm) averaged over the opening of the hood is achieved when the movable sash is placed at the marked working height of 18 inches. Sash heights greater than 18 inches produce an airflow rate below 100 fpm, which is not suitable for working with hazardous materials. Sash heights greater than 18 inches may be used for installation of equipment and other operations that do not present a chemical exposure hazard. All hoods are required to have at least one type of continuous monitoring device designed to provide the user with current information on the operational status of the fume hood. CAV hoods will have one of the following performance indicators attached to them: magnehelic gauges or electronic flow alarms, shown in figure 3.6. Magnehelic gauges do not provide an audible alarm when the flow rate of the fume hood has deviated from normal. Rather the user must visually check the gauge for deviations. The electronic flow alarms have an audible alarm that alerts the user of hood malfunction.

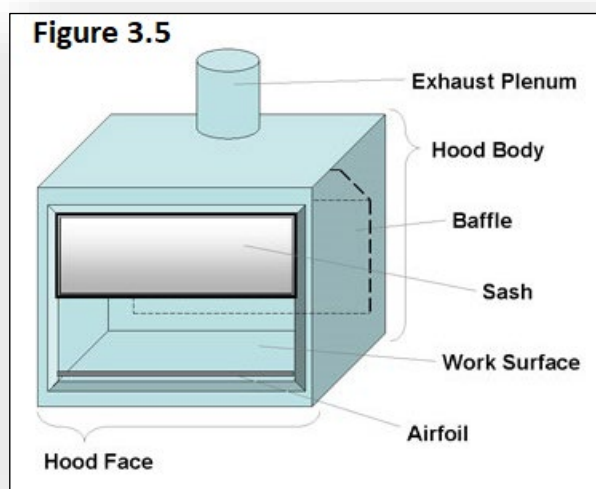
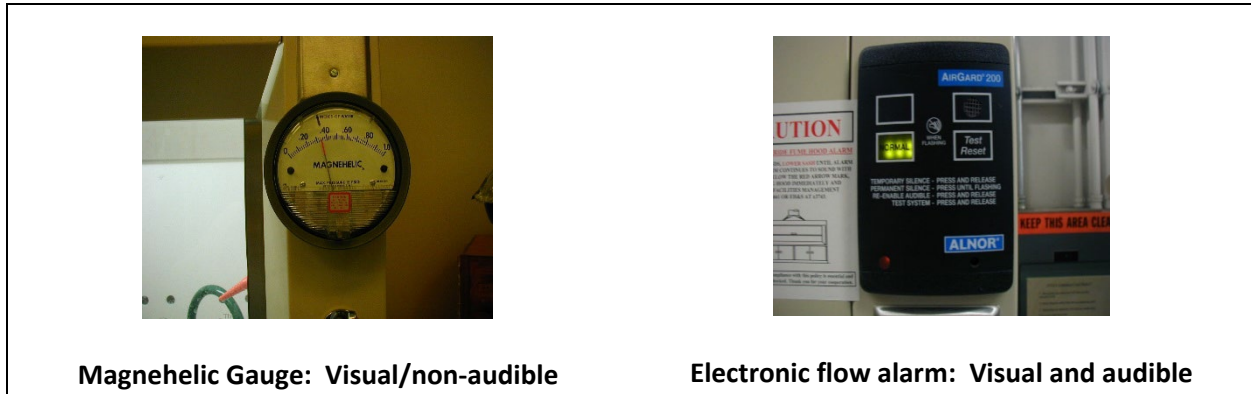

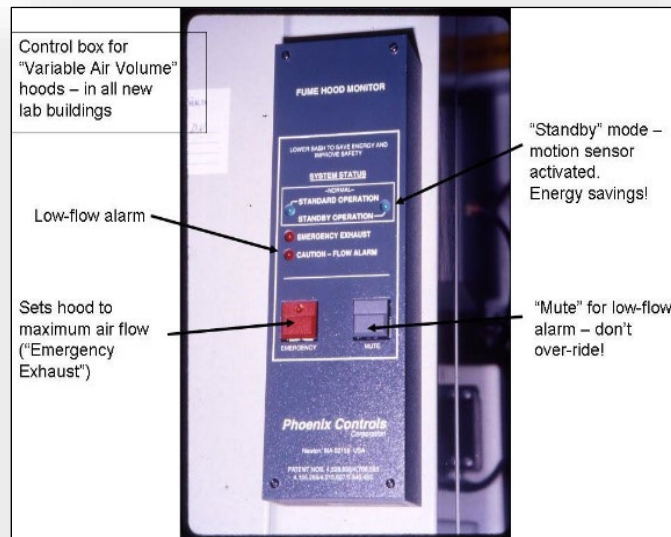

Figure 3.6



Variable Air Volume (VAV) hoods are equipped with valves and sash height sensors that allow the hood to achieve 100 fpm at any sash height. However, this is an energy saving feature, and the working sash height is still 18 inches. The presence of the sash created a barrier between the worker and the materials in the hood and therefore protects from splash hazards, etc. For VAV hoods, the required monitoring device consists of a hood monitor box as shown in figure 3.7. In addition to providing an audible alarm indicating inappropriate airflow, it also has indicators for when the hood is in 'standby mode' (no worker present, airflow at 60 fpm) vs. standard mode (worker presence detected by motion detector, airflow at 100 fpm average). These hoods also have an 'emergency exhaust' button which ramps the airflow up to maximum. This setting should only be used during emergencies, as it can disrupt and knock over items in the hood.

Figure 3.7



Additional fume hood types include those designed for use with strong corrosives like hydrofluoric acid (acid hoods), and the potentially explosive perchloric acid (Perchloric acid wash-down hoods). If you are using either of these materials, please contact EH&S for a hazard assessment and safety equipment evaluation.

Fume hoods should be used when working with all hazardous substances. In addition, a fume hood or other suitable containment device **must** be used for all work with Particularly Hazardous Substances (PHS). A properly operating and correctly used fume hood can reduce or eliminate inhalation hazards present when working with volatile liquids, dusts and mists. When hazardous materials are present in a hood, but it is not under active use (such as during unattended operations), the movable sash should be completely closed. Fume hoods are not designed to be used as storage areas, and are not to be used as such unless no other operations are conducted in that hood.

### **General Rules for Fume Hood Use**

- 1. Fume hoods should not be used unless they have a certification sticker that is dated within the past year.**
- 2. Before beginning work, check the hood monitoring device to confirm proper hood function.**
- 3. Always keep hazardous materials >6 inches behind the plane of the sash.**
- 4. Work with the movable sash at the marked 18 inch working height.**
- 5. For walk-in style hoods, where the hood and sashes extend to the floor of the lab, keep the sash opening as small as possible as a large opening can create difficulty in maintaining airflow and allows for turbulence.**
- 6. Do not clutter your hood, as this blocks airflow and provides fuel for any potential lab fire. Only materials actively in use should be present.**
- 7. Do not modify hood, duct work, or the exhaust system without prior EH&S approval.**
- 8. Do not use hood as a storage area for chemicals or large equipment unless the hood is dedicated to one of these functions.**
- 9. Close the sash when the hood is not in active use.**

Fume hoods are evaluated for operation and certified by EH&S on an annual basis. Hoods certified for use with certain [regulated carcinogens](#) are evaluated semi-annually. These evaluations verify the proper fume hood air flow velocity (100 fpm) to ensure that the unit will operate as designed. Data on fume hood monitoring is maintained by EH&S. Additionally, they must be inspected upon installation, renovation, a problem is reported, or a change has been made to the operating characteristics of the hood. A fume hood must have a current calibration sticker and a marker indicated the sash height to be used when working with hazardous materials (18 inches). If these labels are missing, do not use the hood, and contact EH&S at 805-893-3194 for an immediate fume hood evaluation. Routine maintenance and repair of fume hoods are conducted by Facilities Management. If any problems with the fume hood occurs, or if the audible alarm is going off, contact Facilities Management at 805-893-8300.

Somewhat related to chemical fume hoods are laminar flow hoods and biosafety cabinets. The key differences are summarized in figure 3.8. Laminar flow hoods generally do not offer personnel protection, and therefore are not considered engineering controls. The exception is exhausted laminar flow hoods, which are connected to building exhaust and do not recycle air back into the laboratory. Biosafety cabinets do offer personnel protection, as well as environmental protection from biohazardous material. Note that many biosafety cabinets recirculate air back into the laboratory after it passes through a high efficiency HEPA filter. These filters do not remove chemical contamination. Therefore, **never use volatile hazardous chemicals in a recirculating biosafety cabinet.** For biosafety cabinets that are exhausted to the outside of the building, keep the use of hazardous chemicals to a minimum, as these cabinets are not designed with chemical fume protection as a primary consideration. Further training on biosafety cabinets is provided in the mandatory [BSL-2 and Blood Borne Pathogen](#) training, as well as hands-on by the PI or delegate.

### Figure 3.8



Protection	Biosafety Cabinet Class II type A2	Chemical Fume Hood	Laminar Flow Hood
Personnel	Yes	Yes	No*
Product	Yes	No	Yes
Environment	Yes	No	No

\*Unless hard-ducted to building exhaust

### Glove Boxes

In addition to fume hoods, some laboratories use glove boxes, also known as dry boxes, for working with reactive chemicals under an inert atmosphere, working with very toxic substances, or for creating a stable, draft-free system for weighing hazardous or reactive materials (Figure 3.9). These units require [specialized, hands-on training](#) on proper use, and this training must be documented.

**Figure 3.9 Glove Box**



### Hazardous Materials Storage Equipment

Beyond the handling of hazardous materials, engineering controls also come into play in the storage of these materials. Due to these strict mandates regarding flammable chemical storage outlined in the California Fire Code, one of the most important storage devices is the flammable storage cabinet (figure 3.10). Others include ‘de-sparked’ refrigerators and freezers, and compressed gas cylinder mounts. These are discussed at length later in this document in the section [Chemical Inventory, Storage and Transport](#).

**Figure 3.10: Flammable Storage Cabinets**

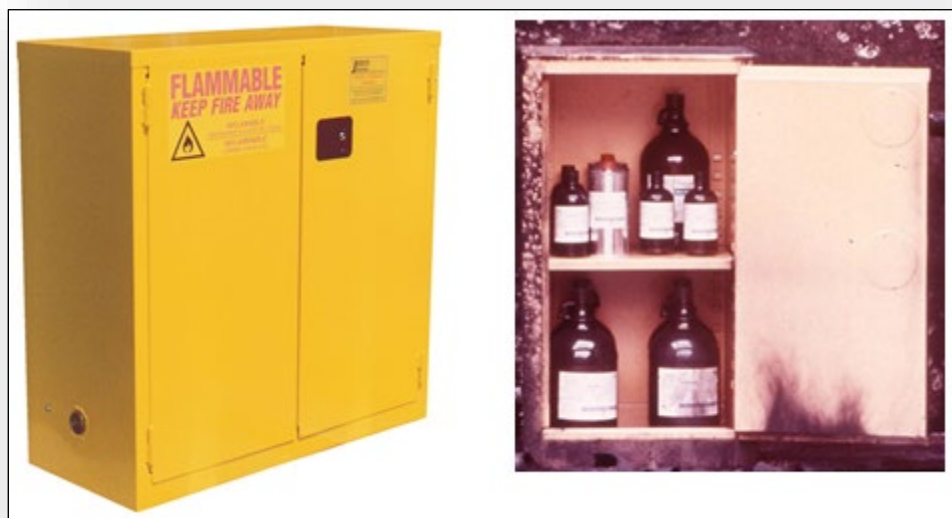

### **Administrative Controls**

Administrative controls consist of policies, procedures and trainings designed to reduce or prevent exposures to laboratory hazards. These controls require the user to exhibit strong situational awareness

and act prudently while in the laboratory. This behavioral element is the reason administrative controls are placed one tier below engineering controls in the [hierarchy of controls](#).

### General Laboratory Practices

PI's/Laboratory Supervisors are strongly encouraged to establish and document clear rules for the following activities:

- *Working alone in the laboratory.* A laboratory-specific Standard Operating Procedure (SOP) that defines those laboratory activities that may not be undertaken while alone in the laboratory should be included with other laboratory SOP's.
- *Unattended laboratory operations:* Some requirements might include a posted description of the operation, the use of a thermocouple and over-temperature shutoff, and the use of flow sensors for cooling water.
- *Modifying a laboratory specific SOP* in such a manner that the overall hazard is increased substantially. A prime example of this is the scale-up of a chemical reaction. It is strongly recommended that the PI/Laboratory Supervisor establish upper limits for the quantities of materials used in the cases of potentially explosive, extremely reactive and acutely toxic chemicals, and require prior approval for work when these limits are exceeded.

### Standard operating Procedures

To supplement the general guidance regarding laboratory work with chemicals that is contained in this Chemical Hygiene Plan, PI's/Laboratory Supervisors are required to develop and implement laboratory-specific SOP's for hazardous chemicals that are used in their laboratories per Cal/OSHA regulation [8 CCR §5191 \(e\)\(3\)\(A\)](#). The development and implementation of SOP's is a core component of promoting a strong safety culture in the laboratory and helps ensure a safe work environment. These SOP's should be written by laboratory personnel who are most knowledgeable and involved with the chemical/operation involved. Completed SOP's must be approved and signed by the PI/Laboratory Supervisor. Factors to consider when writing an SOP, in addition to the hazards inherent to the material, include frequency of use, ranges in scale, temperature, and pressure, and *circumstances requiring prior approval by the PI/Laboratory Supervisor*. To assist researchers with this effort, an [SOP template library](#) has been created that contains templates that cover all hazard classes of chemicals, plus a number of chemical specific SOP's. EH&S is available to assist researchers in filling out the required fields and thereby creating a completed SOP, and in developing an SOP from scratch if a suitable template is not available.

SOP's shall be reviewed, and revised as needed, when one of the following criteria is met:

- Hazard level is altered due to changes in experimental conditions such as temperature, pressure, or scale.

- Equipment changes.
- An unexpected outcome occurs, resulting in a reassessment of the hazard/risk profile.

SOPs should be maintained along with this Chemical Hygiene Plan in hardcopy and/or electronic format and be readily available to laboratory personnel. All lab members must read and sign the Chemical Hygiene Plan and their research group's associated SOP's before entering the laboratory.

### Particularly Hazardous Substances

Additional administrative controls must be implemented in order to work safely with PHS's. These include:

- Establishment of designated areas.
  - Can be as small as a single fume hood, but often encompasses the entire lab.
  - Only personnel trained on PHS use have access to the designated area.
  - The designated area should be designed in a way that will contain spills to that area.
- Containment devices (e.g. fume hoods) MUST be used at all times while handling PHS, to ensure there is no worker exposure.
- Segregated and clearly labeled storage areas exclusively for PHS must be provided.
- Procedures for contaminated waste disposal.
- Decontamination procedures must be followed: Work surfaces should be decontaminated upon completion of work. Soap and water are effective for removing most chemical residues, however some chemicals require the use of specific agents (e.g. hypophosphorous acid for inactivation of ethidium bromide).

A [searchable list of Particularly Hazardous Substances](#) has been generated by EH&S and is updated annually.

### Laboratory Hazard Assessments

As mentioned previously, each PI/Laboratory Supervisor with assigned laboratory space is required to create a hazard assessment for their laboratory. The online [ASSESSMENT](#) tool is used to generate and document this assessment, as well as to share this assessment with all group members. In addition to being an administrative control, at UC Santa Barbara it has the additional role of determining what forms of personal protective equipment are necessary to protect the workers from the hazards identified.

## Personal Protective Equipment and Appropriate Laboratory Attire

Personal Protective Equipment (PPE) serves as a researcher's last line of defense against chemical exposures and is required by everyone entering a laboratory containing hazardous chemicals. Specific requirements for PPE use and proper laboratory attire are outlined in the [UC Personal Protective Equipment Policy](#). These requirements include, but are not limited to:

- Full length pants and close-toed shoes, or their equivalent.
- Protective gloves, laboratory coats, and eye protection when working with, or adjacent to, hazardous chemicals.
- Flame resistant laboratory coats when working with high hazard materials, pyrophorics, and flammables.

The goal of PPE is to reduce the risk associated with handling hazardous materials and conducting hazardous operations. In some cases, PPE beyond that described above will be required. For example, in cases of high splash hazard, chemical safety goggles may be required in the place of safety glasses, as the goggles form a seal around the face which isolates the eyes more completely from the hazard.

*Note that prescription street glasses are not adequate eye protection in the laboratory!* The lack of side shields and impact resistant lenses leaves the workers eyes exposed to hazards and susceptible to injury. Safety glasses must have these features and possess the ANSI Z87.1 certification stamp on the lenses or frames to be considered protective eyewear. Wearers of prescription glasses can either purchase prescription safety glasses, or wear over-the-glasses safety glasses or goggles.

The specific type of PPE needed for each worker is determined by the laboratory hazard assessment created by the PI/Laboratory Supervisor in the ASSESSMENT tool. Upon logging on, the worker will be directed to read the hazard assessment and watch a brief PPE training video. **A PPE voucher will then be generated by the tool which lists the required PPE for that worker.**

**This voucher can be redeemed for free PPE at the campus PPE distribution center located in the Chemistry Building (557) room 1432.** This process also documents the issuance of the PPE to that individual.

### How to Use and Maintain PPE

PPE should be kept clean and stored in an area where it will not be contaminated. PPE should be inspected prior to use to ensure it is in good condition. It should fit properly and be worn properly. If it becomes contaminated or damaged, it should be cleaned or repaired when possible, or discarded and replaced.





Gloves should be used under the specific condition for which they are designed, as no glove is impervious to all chemicals. Single-use disposable gloves protect only from incidental exposure (e.g. a drop of liquid on the glove) and generally only provide protection for a few seconds. Once contaminated, the glove should quickly be removed and disposed of, the hands washed, and a fresh pair of disposable gloves donned. These gloves should not be used for any operation in which immersion or soaking of the glove is expected, such as rinsing glassware with acetone. For these operations, the appropriate thicker, multiple-use glove should be used (butyl gloves for the acetone example given). Glove manufacturers generally provide glove compatibility charts for their products. Some useful examples are:

- [Microflex Chemical Resistance Guide](#)
- [Cole Parmer Safety Glove Chemical Compatibility Database](#)
- [Ansell Guardian Partner Chemical Protection Guide](#)

In cases where spills or splashes of hazardous chemicals on clothing or PPE occur, the clothing/PPE should immediately be removed and placed in a closed container to prevent further release of the chemical. Heavily contaminated clothing/PPE, as well as PPE contaminated with particularly hazardous substances ([PHS](#)) should be disposed of as hazardous waste. Non-heavily contaminated laboratory coats should be cleaned and properly laundered. **Coats can be dropped off at any of eight [designated laundry locations](#) on campus. The clean coats are returned to the same drop-off location within two weeks.** Under no circumstances should laboratory coats be laundered at home or at commercial laundromats.

### Respiratory Protection

Typically, respiratory protection is not needed in a laboratory. Under most circumstances, safe work practices, small scale usage, and engineering controls (fume hoods, biosafety cabinets, and general ventilation) adequately protect laboratory workers from inhalation hazards. Under certain circumstances, however, respiratory protection may be needed.

Per Cal/OSHA regulation [8 CCR §5144](#) and [UCSB Campus Policy](#), *all UCSB personnel who use respiratory protection equipment including filtering facepiece respirators (dust masks) shall be included in the UCSB [Respiratory Protection Program](#).* The primary objective of the UCSB Respiratory Protection Program is to prevent harmful exposures to hazardous atmospheres through:

- Elimination of hazardous atmospheres wherever possible through the implementation of effective control measures.



- Where adequate control measures are not feasible, the use of respiratory protection to ensure exposures to hazardous atmospheres do not exceed applicable exposure limits.

Respiratory protection must be selected carefully as most respirators only provide protection against certain types of contaminants within specific concentration ranges. The [UCSB Respiratory Protection Manual](#) outlines local requirements for respirator use by campus personnel. These requirements include respirator training, fit testing and a medical evaluation.

The Office of Environmental Health and Safety shall act as the sole source for purchasing, fitting and approving the use of all respiratory protection equipment on campus.

## Good Laboratory Practices

In order to maintain a safe workplace, certain basic working habits must be exercised. In the laboratory setting these practices and behaviors address the reduction in risks associated with chemicals, equipment, and sources of physical hazards such as electricity, among other things. Some of these habits are described below.

### Chemical Handling

- Use only those chemicals for which the available ventilation system is appropriate. If you are unsure, contact EH&S.
- Review all relevant SDS's and SOP's before beginning a novel operation.
- Properly label and store all chemicals. All chemicals not in immediate use should be in their storage area, not on lab benches or fume hoods.
- Dispose of hazardous waste according to [UCSB waste disposal procedure](#). Do not pour hazardous waste down the drain.
- Be prepared for an accident or spill and refer to the emergency response procedures for the specific material. Information on minor spill mitigation can be found in Chapter 4. For larger spills, or if you are not comfortable addressing the spill for any reason, contact EH&S. In the case of personnel exposure to the:
  - EYE: Promptly flush eyes with water for 15 minutes, then seek medical attention. Bring SDS with you to the medical facility.
  - SKIN: Promptly flush the affected areas for 15 minutes and remove any contaminated clothing, then seek medical attention. Bring SDS with you to the medical facility.

## Physical Hazard Handling

In addition to chemical hazards, there are a number of physical hazards that are common in the laboratory setting. These include: pressure and vacuum, sharps, electricity, noise, vibration, temperature extremes, and kinetic energy. Some good practices relating to these physical hazards are:

- Store laboratory glassware with care. Inspect all glassware and other equipment before use; do not use damaged items.
- Use proper syringe techniques. Do not re-sheath used disposable needles.
- Compressed gas cylinders: inspect for damage/corrosion on a regular basis. Use a pressure regulator that is compatible with the gas being used. Check plumbing for leaks. Be aware of the possibility of an oxygen deficient atmosphere being created if the full contents of the cylinder are released rapidly, as upon rupture of the cylinder. Carbon monoxide detectors are easy to purchase and relatively inexpensive. When using carbon monoxide, place a CO detector near plumbing joints or other areas where a leak might occur. Contact EH&S to assess the need for oxygen or other gas monitors.
- Cryogenics (Liquid nitrogen and helium, dry ice): Store and transfer only in approved storage vessels. Wear cryogenic gloves when handling. A face shield may be required if there is a significant splash hazard. Be aware of the possibility of an oxygen deficient atmosphere upon the evaporation of the cryogen. Contact EH&S to assess the need for oxygen or other gas monitors.
- Shielding: In situations where explosion (high pressure or high reactivity) or implosion (vacuum) are a possibility, use appropriate shielding to protect from flying fragments and other material. Use extra care with Dewar flasks and other evacuated glass apparatus; shield or wrap them to contain chemicals and fragments should implosion occur.
- Electrical Hazards: Do not overload circuits. Do not 'daisy chain' extension cords or power strips. Examine wires for fraying. Do not use extension cords as permanent wiring. Contact Facilities if additional electrical outlets are needed.
- Noise: Loud workspaces are [assessed by EH&S](#), and hearing protection is provided as necessary.

## General Laboratory Operations

- Good housekeeping is key to a safe laboratory. Some good practices include:
  - Keeping work areas, especially fume hoods, clean and uncluttered.
  - Preventing the accumulation of dirty glassware, unneeded samples, and trash.

- Keeping aisles and areas around safety shower/eyewash units clear to allow unobstructed exit and easy access to safety equipment in an emergency.
- Practicing good refrigerator/freezer management by preventing overcrowding, using secondary containment, and completing periodic defrosting procedures.
- Prudent laboratory behavior is also important. Examples include:
  - Do not engage in distracting behavior such as practical jokes in the laboratory, as this can distract or startle other workers.
  - Wash your hands often, and again before leaving the laboratory.
  - Avoid working alone in the laboratory. If work must be conducted alone, restrict this work to that which does not involve significant chemical or physical hazards.
  - Do not bring or consume food/drink in any areas where hazardous materials are stored and handled.
  - Do not handle personal mobile devices while wearing gloves. Do not set a mobile device down on any surface in the lab which may be contaminated with hazardous chemicals.
- Seek information and advice about hazards, plan appropriate protective procedures, and plan positioning of equipment before beginning any new operation.
- Be alert to unsafe conditions and ensure that they are corrected when detected.
- If minors are in the laboratory, be sure to follow the UC Policy on [Minors in Laboratories and Shops](#).
- For unattended laboratory operations, ensure that the operation has been approved by the PI/Laboratory Supervisor, the lab or fume hood door has signage in place describing the operation and associated hazards, the lights are left on, and make provisions for the loss of utility service (electricity, flowing water).
- Do not disturb equipment in use or any other laboratory operation without the consent of the user.
- Report all accidents, injuries and near-misses to the PI/Laboratory Supervisor and [to EH&S](#). We cannot learn from these incidents if they are not reported.



- Report all fires to EH&S, and the discharge of any fire extinguisher to Facilities Management at 805.893.8300

## Chemical Inventory, Storage, and Transport

### Chemical Inventory

An accurate chemical inventory is a necessary part of a healthy chemical hygiene program. Certain minimum requirements for the quality and quantity of chemical inventory data are set by a variety of regulatory agencies. These are:

#### Local regulations (Santa Barbara County Environmental Health Services)

- [Hazardous Materials Business Plan](#): The County requires businesses to provide information about their bulk hazardous materials, including location, physical state, container type, amount present and maximum amount stored on site during the year. The County uses the information for emergency response planning. For UCSB laboratories and shops to be in compliance they must report any hazardous materials to EH&S which at any one time during the year will be stored in quantities greater than:
  - 500 pounds of a solid.
  - 55 gallons of a liquid.
  - 200 cubic feet of a compressed gas, excluding inert gases, when the volume is calculated at standard temperature and pressure (STP).
- [California Accidental Release Prevention Program \(CalARP\)](#): The purpose of the CalARP program is to prevent accidental release of substances that can cause serious harm to the public and the environment. As such, businesses that handle more than a threshold quantity of a regulated substance are required to report this to the County, and to develop a Risk Management Plan (RMP).

#### State Regulations

- [The California Fire Code \(CFC\)](#): Title 24 of the California Fire Code defines Maximum Allowable Quantities (MAQ) for certain classes of chemicals, including flammables, oxidizers, pyrophoric/water reactive materials and highly toxic materials. The MAQ's vary depending on building construction and floor above or below ground, and therefore both quantities and location data must be collected for these materials.
- [Regulated Carcinogens \(Cal/OSHA\)](#): These chemicals have very specific handling requirements, including the establishment of designated areas. Therefore, their presence and location on campus must be documented.

#### Federal Regulations

- [Chemical Facility Anti-Terrorism Standards \(CFATS\)](#): This standard covers a list of chemicals that are of interest to the Department of Homeland Security. The campus is required to report to DHS upon crossing designated threshold amounts of these chemicals. These quantities are calculated for the campus as a whole.

To obtain the data required to comply with these mandated programs, EH&S reviews the annual [Laboratory Hazardous Materials Survey](#) with each PI/Laboratory Supervisor during the annual laboratory safety review. All of the required data as described above is compiled via these survey forms, and entered into [UC Chemicals](#), a web-based chemical inventory database.

*UC Chemicals can also be used directly by the research groups to manage their entire chemical inventory.* This is best practice, and encouraged by UC Santa Barbara. Having a complete real-time inventory of all the chemicals in a laboratory, as opposed to just the chemicals required by the above regulations, has a number of benefits. First, it gives the researchers a high-resolution knowledge of all of the chemical hazards present in the laboratory. Second, it aids in the financial and time management of laboratory activities by reducing duplicate ordering, and avoiding delays caused by awaiting the delivery of a chemical reagent that is actually already present in the laboratory. Finally, it helps reduce diversion of chemicals (acquisition for illegitimate or illegal purposes).

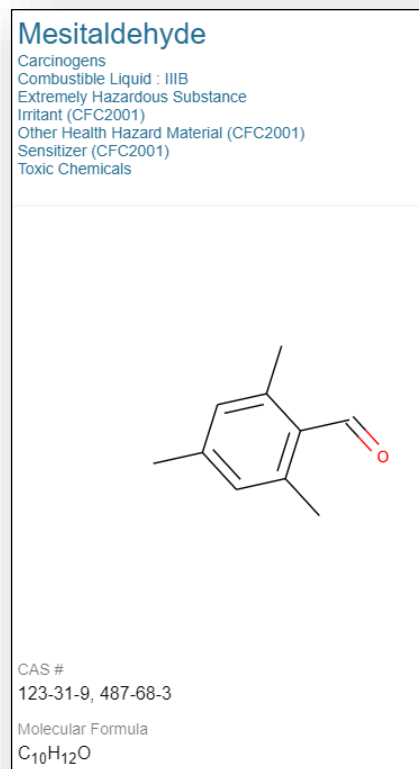

### Chemical Storage

It is important to establish and follow safe chemical storage and segregation procedures in the laboratory. Storage guidelines for flammable, oxidizing, corrosive, water reactive, explosive and acutely toxic materials are described in the following sections. The specific SDS should always be consulted when doubts arise concerning chemical properties, compatibilities, associated hazards, and storage recommendations. All storage procedures must comply with Cal/OSHA, Fire Code and building code regulations. Figure 3.11 shows the properties to be taken into consideration when developing a storage plan, in order of priority.

**Figure 3.11**

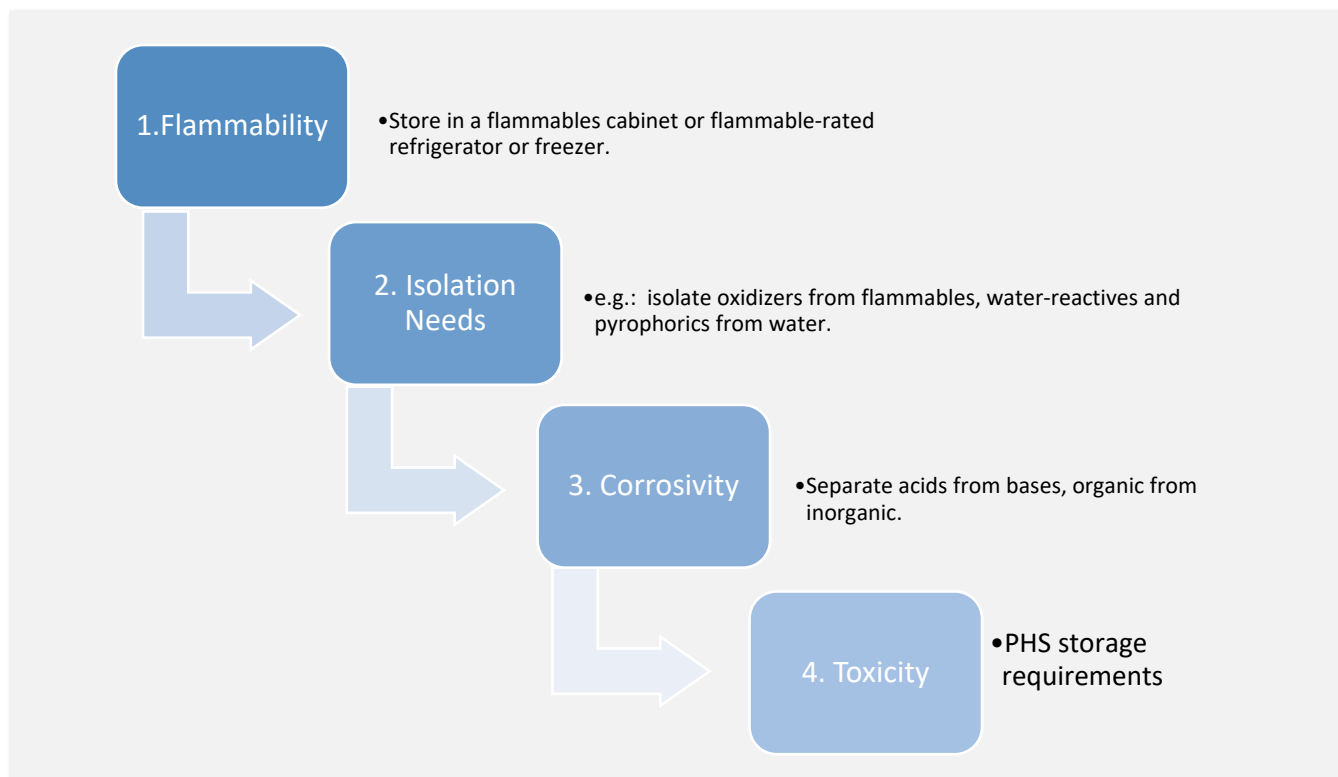

### General Recommendations

Each chemical in the laboratory should be stored in a specific location and returned there after each use. Acceptable chemical storage locations may include corrosive cabinets, flammables cabinets, laboratory shelves, or appropriate refrigerators and freezers. Chemicals should not be routinely stored on laboratory benchtops or on the floor. Fume hoods should not be used as general storage areas for chemicals, as this seriously impairs the ventilating capacity of the hood (Figure 3.12)

To avoid overcrowding and unnecessary risk, chemicals should be reviewed periodically, and compromised items removed as chemical waste. Some indications for disposal include:

- Cloudiness in liquids
- Color change
- Evidence of liquids in solid material, or solids in liquid material
- 'Puddling' of material around outside of containers
- Obvious deterioration of containers

Figure 3.12



Laboratory shelves should have a raised lip or railing along the outer edge to prevent containers from falling. Hazardous liquids or corrosive chemicals should not be stored on shelves above eye-level, and

chemicals that are corrosive or highly toxic should be stored in secondary containment. Chemicals must be stored at an appropriate temperature and humidity level and should never be stored in direct sunlight or near heat sources, such as laboratory ovens and furnaces.

Incompatible materials should be stored in separate cabinets, whenever possible. If these chemicals must be stored in one cabinet due to space limitations, adequate segregation and secondary containment must be ensured to eliminate the possibility of mixing. Figure 3.13 shows some common chemicals and their storage compatibilities. More detailed information can be found in [Prudent Practices Chapter 5, Section 5.E.2. and Table 5.1](#). All stored containers and research samples must be appropriately labeled and tightly capped to prevent vapor interactions and to alleviate nuisance odors. Storing chemicals in flasks with cork, rubber or glass stoppers should be avoided due to the potential for leakage.

Figure 3.13

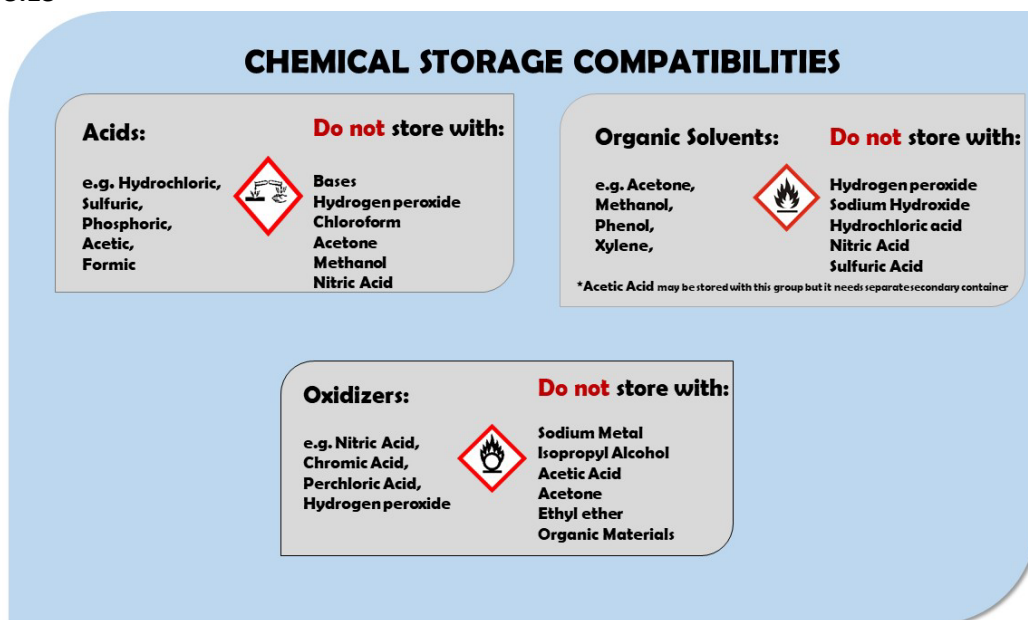

Laboratory refrigerators and freezers must be labeled as “No Food or Drink”. Freezers should be defrosted periodically so that chemicals do not become trapped in ice formations.

### Flammable and Combustible Liquids

The California Fire Code addresses how much total volume of flammable materials can be stored in a room, floor, or building as a whole. As such, large quantities of flammable or combustible materials should not be stored in the laboratory. No more than **10 gallons** of flammable or combustible liquids, including hazardous waste, are allowed to be kept outside of a flammable storage cabinet, safety can, or approved refrigerator/freezer. The maximum total quantity of NFPA Class 1A flammable liquids within a safety cabinet must not exceed **60 gallons**. These are materials with a flashpoint below 73 °F





(22.8 °C) and boiling points below 100 °F (37.8 °C) such as pentane, diethyl ether, etc. The total volume within a cabinet must not exceed **120 gallons** per cabinet.

For flammable materials that require low temperature storage, specialized refrigerators or freezers are used. These ‘de-sparked’ or ‘explosion proof’ units are specially designed so that no potential source of ignition is present inside the unit (lightbulbs, switches, thermostat knobs, etc.). This is necessary due to the very low flashpoint and high volatility of many flammable liquids. Build-up of fumes inside the unventilated unit, followed by a spark caused by the lightbulb or the compressor turning on is a known cause of multiple laboratory explosions. As standard refrigerators and freezers are also present in the laboratory for non-flammable storage, it is important to be able to distinguish between the two. Figure 3.14 shows the standard warning label placed on all refrigerators that are not suitable for flammable storage. Other identifiers include the presence of lightbulbs, switches and other controls inside the unit. If you are uncertain whether or not a unit is safe for flammable storage, contact EH&S.

Figure 3.14



Always segregate flammable or combustible liquids from oxidizing acids and oxidizers (e.g. nitric acid). Flammable liquids or gases must never be stored in domestic-type refrigerators/freezers. Flammable or combustible liquids must not be stored on the floor or in any exit access. Handle them only in areas free of ignition sources, and in a fume hood whenever possible. Only the amount of material required for the procedure should be stored in the work area.

Static electricity is a concern when handling flammable and combustible liquids, as a small spark is often sufficient to act as an ignition source. Metal drums must be grounded and bonded during the dispensing process, and a metal pump should be used. Avoid pouring directly from metal drums.

#### Pyrophoric and Water Reactive Materials

Because pyrophoric substances can spontaneously ignite on contact with air and/or water, they must be handled under an inert atmosphere and in such a way that rigorously excludes air and moisture. Some pyrophoric materials are also toxic and many are dissolved or immersed in a flammable solvent. Other common hazards include corrosivity, teratogenicity, or peroxide formation. **Before working with pyrophoric materials, individuals must demonstrate knowledge of the appropriate methods to handle, transfer, and quench the material being used.**

Only minimal amounts of reactive chemicals should be used in experiments or stored in the laboratory. These chemicals must be stored as recommended in the SDS. Suitable storage locations may include inert gas-filled desiccators, glove boxes, or a flammable substance approved refrigerator/freezer. Reactive material containers must be clearly labeled with the correct chemical name, in English, along with a hazard warning. If pyrophoric or water reactive reagents are received in a specially designed shipping, storage or dispensing container (e.g. Aldrich Sure/Seal™ packaging system) ensure that the integrity of that container is maintained. Ensure that sufficient protective solvent, oil, kerosene, or inert

gas remains in the container. Never store reactive chemicals with flammable materials or in a flammable liquid storage cabinet.

Storage of pyrophoric gases is described in the California Fire Code, Chapter 41, and requires gas cabinets with remote sensors and fire suppression. Gas flow, purge and exhaust systems must also have redundant controls to prevent the pyrophoric gas from igniting or exploding. Emergency back-up power should be provided for all electrical controls, alarms and safeguards associated with the pyrophoric gas storage and process systems. *As such, purchase of pyrophoric gases is restricted and requires EH&S approval via the Gateway purchasing system to ensure the necessary infrastructure is in place before the arrival of the material.*

### Oxidizers

Oxidizers such as hydrogen peroxide, halogen gas, potassium permanganate, sodium nitrate, nitric acid, perchloric acid, etc. should be stored in a cool, dry place and kept away from flammable and combustible materials including wood and paper, Styrofoam, plastics, flammable organic chemicals, and away from reducing agents such as zinc, alkali metals, metal hydrides and formic acid.



Vented caps must be used on containers for waste streams of oxidizing inorganic acids or pressure-generating materials (nitric acid, aqua regia piranha etc). These requirements are outlined in the [SOP templates](#) for these materials

### Peroxide Forming Chemicals (Time-Sensitive Materials)

Peroxide forming chemicals (ethereal solvents, cyclohexene, etc.) should be stored in airtight containers in a dark, cool and dry place and must be segregated from other classes of chemicals that could create a serious hazard to life or property should an accident occur (e.g. acids, bases, oxidizers). All containers should be labeled with the date received and the date opened. This information, along with the chemical identity, should face forward to minimize handling during inspection. Minimize the quantity of peroxide forming chemicals stored in the laboratory and dispose of them before peroxide formation occurs. Refer to the '[Hazard Classes – Peroxide Forming Chemicals](#)' section of this document for information on expiration times for the different classes of peroxide formers. Carefully review all cautionary materials supplied by the manufacturer prior to use. Avoid evaporation or distillation, as distillation defeats the stabilizer added to the solvents. Ensure that containers are tightly sealed to avoid evaporation and that they are free of exterior contamination or crystallization.

Do not handle a container of peroxide forming chemicals if:

- If it greater than five years old, or of undetermined age.
- Crystallization is present in or on the exterior of the container.
- An oily second layer is present in the container.

In this situation, immediately restrict access to the area and contact EH&S.

### Potentially Explosive Chemicals

Potentially explosive chemicals such as dibenzoyl peroxide, trinitrobenzene, picric acid and salts, and perchloric acid and salts, should be stored at the manufacturers' recommended temperature in an explosion-proof refrigerator, freezer or cabinet. They should be kept away from heat, light, friction, impact, and any other potential initiating mechanisms. They should be stored away from flammable and combustible materials. Picric acid and perchloric acid should be kept away from metals and metal salts, with which they can react to form highly explosive products. Picric acid becomes most explosive when dry, and therefore must contain at least 10% water for inhibition. If a bottle of Picric acid of unknown age or condition is found in the lab, isolate the area and contact EH&S. Perchloric acid should be stored by itself, away from all other chemicals.



### Corrosives

Store corrosive chemicals (acids, bases) below eye level and in secondary containers that are large enough to contain either 10% of the total volume of liquid stored, or the volume of the largest container, whichever is greater. Acids must be segregated from bases and from active metals such as sodium, potassium and magnesium, as well as from chemicals which could generate toxic gases upon contact such as sodium cyanide and iron sulfide. Additionally, mineral acids must be kept away from organic acids, and oxidizing acids must be segregated from flammable and combustible substances.



### Compressed Gases

Compressed gas cylinders must be mounted to a bracket or rack that has been bolted to a structural component of the building, or to casework that is itself bolted to the structure. The cylinder must be held in place by two chains, at 1/3 and at 2/3 height. The safety cap must be in place unless the gas is currently in use (regulator attached). All connections must be inspected frequently. Never use a compressed gas cylinder without a regulator. For toxic gases, a gas cabinet provides a storage area that is ventilated to the exterior of the building in case of a leak or rupture (Figure 3.15).



**Figure 3.15: Gas Cylinder Storage**



Even an inert, non-toxic gas like nitrogen poses an asphyxiation risk if the pressure in a nitrogen tank is released suddenly enough to overwhelm room ventilation when present in confined spaces (an elevator or closet) or in poorly ventilated areas (a cold room). Contact EH&S prior to locating cryogenic liquids in these areas to assess if oxygen monitoring is necessary.

For toxic gases, a gas cabinet provides a storage area that is ventilated to the exterior of the building in case of a leak or rupture. Flammable gas cylinders must use only flame-resistant gas lines and hoses, and must have all connections leak-tested. Compressed oxygen gas cylinders must be stored at least 20 feet away from combustible materials and flammable gases, or be separated by a non-combustible partition.

Corrosive gases should be consumed or disposed of within 2 years due to the potential of cylinder failure. This failure can occur via two routes. One is that some acids slowly build up dangerous pressures of hydrogen gas via reaction with the metal cylinder walls resulting in explosion (e.g. HF). The other is the corrosion of the metal components of the cylinder resulting in leaks or frozen valves.

### Cryogenics

Because cryogenic liquid (e.g. Nitrogen, Argon, Helium, etc.) containers are at low pressure and have protective rings mounted around the regulator, they are not required to be affixed to a permanent fixture such as a wall. However, additional protection considerations should be addressed when storing cryogenic liquids in a laboratory. The primary risk to laboratory personnel from cryogenic liquids is skin or eye damage caused by contact with the material. Always wear eye/face protection and thermally insulated gloves while handling these materials. Additionally, all cryogenic liquids have large expansion volumes, typically greater than 500:1 when transitioning from a cryogenic liquid to a gas at standard temperature and pressure. This volumetric increase can create two types of hazard:

- High pressure: Use only specially designed containers, and ensure that pressure relief valves are functional and unobstructed before use.
- Oxygen displacement: As is the case for inert compressed gases, while usually non-toxic, there is an asphyxiation risk when cryogenic liquids are present in confined spaces (an elevator or closet) or in poorly ventilated areas (a cold room). Contact EH&S prior to locating cryogenic liquids in these areas to assess if oxygen monitoring is necessary.

## Transporting Chemicals

### On-Campus Transport of Hazardous Chemicals

Precautions must be taken when transporting substances between laboratories. Chemicals must be transported in break-resistant secondary containers such as commercially available bottle carriers that include a carrying handle, or plastic tubs on a sturdy cart with a railing. Chemicals must not be left unattended. Ensure that your destination is accessible before departing.

**Figure 3.16**

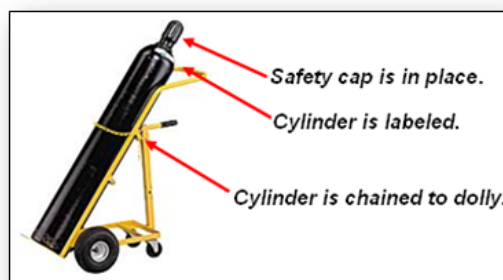

When transporting compressed gas cylinders (Figure 3.16):

- Disconnect regulators and other apparatus prior to transport.
- Always replace the valve safety cap before transporting cylinders.
- Cylinders must always be transported using a hand truck or cart designed for that purpose.
- Transport cylinders upright.

When transporting compressed gases *on elevators*, use service or freight elevators when available. In addition, when transporting compressed gases by elevator:

- Post a sign reading “DO NOT ENTER – GAS TRANSPORT” to exclude passengers. Send the elevator to the desired floor, but do not enter the elevator yourself.
- When possible, have someone send the elevator up while another person waits on the receiving floor to take the cylinder out of the elevator. If this is not possible, another plan should be devised to ensure that the cylinder is taken out of the elevator once it reaches the desired floor.

### Off-Campus Transport or Shipment of Hazardous Chemicals

The transport of hazardous chemicals and compressed gases over public roads or by air is strictly governed by international, federal, and state regulatory agencies, including the U.S. Department of Transportation (DOT) and the International Air Transport Association (IATA). Any person who prepares and/or ships these types of materials must ensure compliance with pertinent regulations regarding training, quantity, packaging, and labeling.

*Without proper training, it is illegal to ship hazardous materials.* Those who violate the hazardous materials shipment regulations are subject to criminal investigation and penalties. UC Santa Barbara personnel who sign hazardous materials manifests, shipping papers, or those who package hazardous materials for shipment must be [trained and certified by EH&S](#).

Individuals who wish to transport hazardous chemicals or compressed gases off-campus using a UC Santa Barbara or personal vehicle should contact EH&S to ensure safety and compliance. Some information can be found [here](#).



### **Chemical Security**

Access to hazardous chemicals should be restricted at all times. At a minimum, these materials must be stored in laboratories or storerooms that are kept locked when laboratory personnel are not present. Other requirements come into play for chemicals that are of interest to the Drug Enforcement Agency ([controlled substances](#)), the Federal Bureau of Investigations ([weapons of mass destruction](#)), and the Department of Homeland Security ([Chemical Facility Anti-Terrorism Standard 'CFATS' Chemicals of Interest](#)). These requirements are elucidated at the time of acquisition of these materials.

Per [Prudent Practices](#), areas of concern related to laboratory security include:

- Theft or diversion of chemicals, biologicals, and radioactive or proprietary materials.
- Theft or diversion of mission-critical or high-value equipment.
- Threats from activist groups.
- Intentional release of, or exposure to, hazardous materials.
- Sabotage or vandalism of chemicals or high-value equipment.
- Loss or release of sensitive information.
- Rogue work or unauthorized laboratory experimentation.

It is each laboratory's responsibility to report any theft of chemicals from their laboratories to EH&S. Reporting to one or more of the above-listed agencies may be required depending on the nature of the material stolen.

# Chemical Exposures: Limits, Assessments, and Medical Evaluations

## Regulatory Overview

Under Article 107 of Title 8, Cal/OSHA requires that all employers, “*measure an employee’s exposure to any substance regulated by a standard which requires monitoring if there is reason to believe that exposure levels for that substance exceed the action level (or in the absence of an action level, the exposure limit).*” Repeated monitoring may be required if initial monitoring identifies exposures over the action level or the permissible exposure limit.

- *Permissible Exposure Limits (PEL)* are the maximum permitted 8 hour Time Weighted Average (TWA) exposure concentration of an airborne contaminant without the use of respiratory protection.
- *Short-Term Exposure Limits (STEL)* are the maximum permitted 15 minute TWA exposure concentration without the use of respiratory protection.
- *Ceiling Limits (C)* are the exposure concentration of an airborne contaminant that may not be exceeded at any time.
- *Action levels (AL)* are exposure levels at which exposure initiates certain required activities such as exposure monitoring and medical surveillance, and are generally a fraction of the permissible exposure limit.

Cal/OSHA has listed established PELs, STELs and Ceiling limits for chemical contaminants identified in [8 CCR §5155 \(Airborne Contaminants\) Table AC-1](#). Cal/OSHA requires that exposures exceeding these levels be controlled in order to prevent harmful health effects. Beyond this list, Cal/OSHA has promulgated specific standards covering several regulated carcinogens, which may include and Action Level (AL), triggering medical surveillance requirements or the imposition of a specific Excursion Limit (such as for asbestos) with a unique measurement of the duration of an exposure.

## Exposure Assessments

All UC Santa Barbara employees require protection from exposure to hazardous chemicals above the PELs, STELs and Ceiling limits. In the absence of sufficient engineering controls, an exposure assessment must be conducted in order to ensure exposure limits are not being exceeded. Cal/OSHA requires the person supervising, directing or evaluating the exposure assessment be competent in the practice of industrial hygiene. Thus, exposure assessments should be performed only by representatives of EH&S.

EH&S utilizes various methods when assessing exposure to hazardous chemicals. These include employee interviews, visual observation of chemical use, evaluation of engineering controls, use of direct reading instrumentation, and the collection of analytical samples from the employee’s breathing zone. The assessment will then look at various ways to minimize an exposure, using a combination of elimination, substitution, engineering controls, administrative controls, and person protective

equipment, listed in order of priority. Personal exposure assessments may be performed under situations including the following:

1. As determined based on EH&S review of chemical inventories, SOP's, Laboratory Hazard Assessment Tool (LHAT) assessments types of engineering controls present, and/or laboratory safety review outcomes.
2. Concern expressed by a chemical user as to whether exposure is minimized or eliminated through the use of engineering controls or administrative practices. The user should then inform his or her PI/Laboratory Supervisor, who will in turn contact EH&S.
3. A regulatory requirement exists to perform an initial and if warranted periodic monitoring.

If you are concerned about exposures to chemicals or other hazards in your laboratory, please contact your EH&S laboratory safety representative to schedule an exposure assessment. ***In the event of any serious injury or exposure, including chemical splash involving skin or eye contact, call 911 to obtain medical treatment immediately.*** Do not wait for an exposure assessment to be performed before seeking medical care.

#### Exposure Assessment Protocol

The EH&S Industrial Hygiene Program conducts exposure assessments for members of the campus community. Per [Cal/OSHA 8 CCR § 340.1](#), employees have a right to observe testing, sampling, monitoring or measuring of employee exposure. They are also allowed access to the records and reports related to the exposure assessment. Exposure assessments may be performed for hazardous chemicals, as well as for physical hazards including noise and heat stress, to determine if exposures are within PELs or other appropriate exposure limits. General protocol for conducting an exposure assessment may include any of the following:

1. Employee interviews.
2. Visual observation of chemical usage and/or laboratory operations.
3. Evaluation of simultaneous exposure to multiple chemicals.
4. Evaluation of potential for absorption through the skin, mucus membranes, or eyes.
5. Evaluation of existing engineering controls.
6. Use of direct reading instrumentation.
7. Collection of analytical samples of concentrations of hazardous chemicals taken from the employee's breathing zone, noise dosimetry collected from an employee's shirt collar, or various forms of radiation dosimetry.



If exposure monitoring determines that an employee's exposure is over the Action Level or PEL for a hazard for which Cal/OSHA has developed a specific standard (e.g. lead, methylene chloride), the medical surveillance provisions of that standard shall be followed (see the *Medical Surveillance* section below). If there is no published PEL, STEL or Ceiling limit, EH&S defers to the *Threshold Limit Values (TLV)* established by the American Conference of Governmental Industrial Hygienists (ACGIH), or the *Recommended Exposure Limits (REL)* established by the National Institute of Occupational Safety & Health (NIOSH). It is the responsibility of the PI/Laboratory Supervisor to ensure that any necessary medical surveillance requirements are met.

#### Notification of Results

The Industrial Hygiene Program will promptly notify the employee and PI/Laboratory Supervisor of the results of the assessment in writing within 15 days, or less if required by regulation, after the receipt of any exposure monitoring results. The Industrial Hygiene Program will establish and maintain accurate records of any measurements taken to monitor exposures for each employee. Records, including monitoring provided by qualified vendors, will be managed in accordance with Cal/OSHA regulation [8 CCR §3204](#).

#### Determination and Implementation of Necessary Controls

When necessary, the results of the assessment will be used by EH&S to determine what control measures are required to reduce the employee's occupational exposure. Particular attention shall be given to the selection of safety control measures for chemicals that are known to be extremely hazardous. Per Cal/OSHA regulation [8 CCR §5141](#) the control of harmful exposures shall be prevented by implementation of control measures in the following order:

1. Elimination, whenever possible.
2. Substitution, whenever possible.
3. Engineering controls, whenever feasible.
4. Administrative controls, whenever engineering controls are not feasible or do not achieve full compliance, and these administrative controls are practical.
5. Personal Protective Equipment, including respiratory protection
  - a. During the time period necessary to install or implement feasible engineering controls.
  - b. When engineering controls and administrative controls fail to achieve full compliance.
  - c. In emergencies.

#### **Medical Evaluations**

All employees, student workers, medical health services volunteers, or laboratory personnel who work with hazardous chemicals shall have an opportunity to receive an employer-provided medical

evaluation, including any supplemental examinations that the evaluating physician deems necessary, under the following circumstances:

- Whenever an employee develops signs or symptoms associated with a hazardous chemical to which they may have been exposed at the work area.
- Where personal monitoring indicates exposure to a hazardous chemical is above the Cal/OSHA AL or PEL, or, if these are not established, the TLV or REL as defined in the previous section.
- Whenever an uncontrolled event takes place in the work area such as a spill, leak, explosion, fire, etc., resulting in the likelihood of exposure to a hazardous chemical.
- Upon reasonable request of the employee to discuss medical issues and health concerns regarding work related exposure to hazardous chemicals.

All work-related medical evaluations and examinations will be performed at the [Sansum Clinic Occupational Medicine Center](#) by licensed physicians or staff under the supervision of a licensed physician. Evaluations and examinations will be provided without cost to the employee, without loss of pay, and at a reasonable time.

#### Information to Provide to the Clinician

At the time of the medical evaluation, the following information should be provided by the employee:

1. Employee ID number.
2. Common and/or IUPAC name of the hazardous chemical to which the individual may have been exposed
- 3. A copy of the [Safety Data Sheet \(SDS\)](#) of the hazardous chemical in question.**
4. A description of the conditions under which the exposure occurred.
5. Quantitative exposure data, if available (e.g. from exposure monitoring).
6. A description of the signs and symptoms of exposure that the employee is experiencing, if any.
7. A history of exposure, including from previous employment and non-occupational activities.
8. Healthcare providers must be informed of any biological materials present in the laboratory.

#### Physician's Written Opinion

For evaluations or examinations required by Cal/OSHA, the employer shall receive a written opinion from the examining physician which shall include the following:

1. Recommendations for further follow-up.

2. Results of the medical examination and any associated tests, if requested by the employee.
3. Any medical condition which may be revealed in the course of the examination which may place the employee at increased risk as a result of exposure to a hazardous chemical found in the workplace.
4. A statement that the employee has been informed by the physician of the results of the consultation or medical examination and any medical condition that may require further examination or treatment.

#### Confidentiality and Individual's Access to Personal Medical Records

All patient medical information is protected by both California and Federal law, and is considered strictly confidential. Sansum Clinic is prohibited from disclosing any patient medical information that is not directly related to the work-related exposure under evaluation, and will not reveal any diagnosis unrelated to the work-related exposure.

- Any patient information disclosed by Sansum Clinic to the employee's supervisor will be limited to information necessary in assessing an employee's return to work, including recommended restrictions in work activities, if any.
- Any patient information disclosed by Sansum Clinic to EH&S will be limited to information necessary to develop a course of exposure monitoring, or perform hazard assessments and incident investigations, if appropriate.

Sansum Clinic will otherwise disclose patient medical information only as required by California and Federal law, such as for Worker's Compensation Insurance claims. *However, each employee has the right to access his/her own personal medical and exposure records.* Sansum Clinic will provide an employee with a copy of his/her medical records upon written request.

#### Medical Surveillance

Medical surveillance is the process of using medical examinations, questionnaires and/or biological monitoring to determine potential changes in health as a result of exposure to a hazardous chemical or other hazards. Certain Cal/OSHA standards require clinical examination as part of medical surveillance when exposure monitoring exceeds an established Action Level or PEL.

Medical Surveillance is required of employees who are routinely exposed to certain hazards as part of their job description (such as asbestos) and may be offered to other employees based upon quantifiable or measured exposure.

Examples of hazards that are monitored through the medical surveillance program include:

- Asbestos
- Beryllium
- Formaldehyde
- Noise (Hearing Conservation Program)
- Radioactive Materials (Bioassay Program)
- Respirator Use

- Lead
- Methylene Chloride
- Other Particularly Hazardous Substances

## Hazardous Chemical Waste Management

In California, hazardous waste is regulated by the Department of Toxic Substance Control (DTSC), a division within the California Environmental Protection Agency (Cal/EPA). Federal EPA regulations also govern certain aspects of hazardous waste management, since most of our waste is treated and disposed out of state. These federal regulations are part of the Resource Conservation and Recovery Act (RCRA). Local enforcement is administered by the Santa Barbara County Department of Public Health via the Certified Unified Program Agency (CUPA).



### UC Santa Barbara Hazardous Waste Program

The [Hazardous Waste Program](#) is responsible for providing cost-effective hazardous waste management in compliance with federal state, and local regulations. It provides waste pickup, emergency spill response and assistance with shipping hazardous materials. Additionally, it is responsible for pollution prevention, regulatory reporting, and maintaining campus emergency response capabilities. Each laboratory user must comply with the [UCSB hazardous waste disposal procedures](#) to ensure that all regulatory requirements are being met. Regularly scheduled waste pick-up service is in place for large volume generators in most buildings with wet labs, however, [pick-ups are also available upon request](#) in those buildings as well as those without scheduled pick-ups. Laboratory personnel are responsible for identifying waste, labeling it, and storing it properly in the laboratory. Laboratory clean-outs/decommissioning and disposal of high hazard compounds (expired peroxide formers, dried picric acid, abandoned unknown chemicals, etc.) must be [scheduled in advance](#).

### Definition of Hazardous Waste

EPA regulations define hazardous waste as substances having one or more of the following characteristics:

- Corrosive:  $\text{pH} \leq 2$  or  $\geq 12.5$
- Ignitable: Liquids with a flash point below  $60\text{ }^{\circ}\text{C}$  or  $140\text{ }^{\circ}\text{F}$ .

- Reactive: unstable, explosive, reacts violently with air and/or water, or releases a toxic gas when in contact with water.
- Toxic: As determined by toxicity testing.

The EPA definition of hazardous waste also extends to the following items:

- Abandoned chemicals.
- Unused or unwanted chemicals.
- Chemicals in compromised containers (ruptured, punctured, corroded, etc.)
- Empty containers that have visible residues.
- Containers with conflicting labeling (dual labeling).
- Unlabeled or unknown chemicals.

Chemicals not in frequent use must be carefully managed to prevent them from being considered a hazardous waste. This is especially true for certain compounds that degrade and destabilize over time and require careful management so that they do not become a safety hazard, as described in the section below entitled 'Waste that Requires Special Handling'.

### **Extremely Hazardous Waste**

Certain compounds meet an additional definition known as 'extremely hazardous waste'. This list of compounds includes carcinogens, pesticides, and reactive compounds, among others. Some examples include cyanides, sodium azide, and hydrofluoric acid. The Federal EPA refers to this waste as 'acutely hazardous waste, but Cal/EPA has published a more detailed list of extremely hazardous waste. Both the state and federal lists are included in the [EH&S List of Extremely Hazardous Waste](#). Note: This list, although having some overlap, should not be confused with the list of [Particularly Hazardous Substances](#) previously addressed in this document.

### **Proper Hazardous Waste Management**

#### Training

All personnel who are responsible for handling, managing or disposing of hazardous waste must complete training. Hazardous Chemical Waste training is a component of the Fundamentals of Laboratory Safety course offered by EH&S both [live](#) and [online](#). This satisfies the training requirement.

However, if further training is desired, there is an additional online [UCSB Hazardous Waste Generator training](#) available through the learning center as well.

### Waste Identification

All the chemical constituents in each hazardous waste stream must be accurately identified by knowledgeable laboratory personnel. *This is a critical safety issue for both laboratory users and the hazardous waste program personnel that collect and process the waste.* Mixing of incompatible waste streams has the potential to create violent reactions and is a common cause of laboratory accidents. If there is uncertainty about the composition of a waste stream resulting from an experimental process, laboratory workers must consult the PI/Laboratory Supervisor or the Chemical Hygiene Officer. In most cases, careful documentation and review of all chemicals products used in the experimental protocol will result in accurate waste stream characterization.

For commercial mixtures, the manufacturer's SDS provides detailed information on each hazardous ingredient present, and also the chemical, physical, and toxicological properties of the ingredient. The [UCSB EH&S website](#) provides access to SDS's for hazardous chemicals.

### Labeling

Every container must be appropriately labeled per hazardous waste program requirements. These include:

- Use the [official campus hazardous waste label](#) and provide all necessary information.
- All hazardous waste containers must be labeled with the words 'Hazardous Waste'.
- All unknowns must be analyzed and their hazardous components identified at the generator's expense. Do not lose track of container contents!
- Waste must be identified by chemical name in English. Labels such as 'Inorganic Waste' and 'Organic Waste' are not adequate. Do not use abbreviations, acronyms, or chemical formulas.
- All constituents in solid and liquid mixtures must be identified, and to the extent possible their concentrations stated.
- The chemical hazard class of the waste must be identified (e.g. flammable, corrosive, oxidizer, etc.)
- Any preexisting labels on the container must be defaced either by removal or by crossing out the information.
- *All containers must be dated with the date on which waste was first stored in the container.* Under no circumstances store hazardous waste in the laboratory for more than 270 days (about 9 months).

### Storage

The hazardous waste storage area in each laboratory is considered a Satellite Accumulation Area (SAA) by the EPA. According to EPA requirements, this area must remain under the control of the persons producing the waste. This means that it should be located in an area that is supervised and is not accessible to the public. Other requirements include:

- Waste must be collected and stored at or near the point of generation.
- According to state law, the maximum amount of waste that can be stored in an SAA is 55 gallons of hazardous waste or 1 quart of extremely hazardous waste. If these volumes are met, the waste must be disposed of within 3 days.
- According to the California Fire Code, the maximum amount of flammable solvents allowed to be stored in a laboratory outside a flammable storage cabinet is 10 gallons. *This figure includes accumulated waste.*
- All waste containers must be kept closed when not in use. Containers should be designed so they can be completely sealed when not in use (no open-top glassware).
- Waste containers must be appropriate for the waste being stored in it. (e.g. do not use a glass container for hydrofluoric acid waste), and the waste streams segregated into compatible constituents.
- Oxidizing inorganic wastes (e.g. nitric acid, chromic acid, perchloric acid) or pressure generating wastes (e.g. piranha etch, aqua regia) must be stored with [vented caps](#) (contact EH&S for free vented caps).
- Liquid waste should be in screw top containers, and not be filled over 80%. Secondary containment should be used at all times.
- Outside surfaces of containers must be clean and free of contamination.
- Gas cylinders and lecture bottles must have regulators removed.
- Sharps must be stored in puncture-proof containers.
- Store containers in a designated location (low traffic, safe, secure, contained, etc.). Label this storage area as [‘Hazardous Waste Storage Area’](#).

### Segregation

All hazardous waste must be managed in a manner that prevents spills and unexpected reactions. Additionally, proper waste segregation can help reduce disposal costs. Proper segregation procedure includes:

- Segregate solids, liquids and gases.
- Further segregate into the following categories:
  - Halogenated Organics
  - Non-halogenated Organics
  - Acids of pH  $\leq 2$
  - Bases of pH  $\geq 12.5$
  - Alkali metals/other water reactive
  - Heavy metal solutions & salts
  - Strong oxidizers
  - Peroxide formers
  - Cyanides
  - Chemical Carcinogens
  - Unstable chemicals
  - Other toxic materials

### Incompatible Waste Streams

Mixing incompatible waste streams, or selecting a container that is not compatible with its contents, is a common cause of accidents in laboratories and waste storage facilities. **Reactive mixtures can rupture containers and explode, resulting in serious injury and property damage.** All chemical constituents and their waste byproducts must be compatible for each waste container generated. Waste tags must be immediately updated when a new constituent is added to a mixed waste container, so that others in the laboratory will be aware and manage it accordingly.

A common incompatible waste stream is the addition of nitric acid to a waste container containing organic solvent. This creates a very exothermic reaction and cause catastrophic container failure/large explosion. Extreme care should be taken with nitric acid waste. Store in dedicated small waste bottles, label them clearly, and dispose of them quickly.

### **Waste Which Requires Special Handling**

#### Sharps and Laboratory Glass Waste

Sharps waste includes any device having acute rigid corners, edges, or protuberances capable of cutting or piercing, including but not limited to hypodermic needles, syringes, razor blades and scalpel blades. Glass items contaminated with biohazards, such as pipettes, microscope slides and capillary tubes are also considered sharps waste. Under no circumstances may sharps waste be disposed of in the normal trash. Sharps waste containers must be rigid, puncture-resistant, lidded and leak-proof when sealed.



Laboratory glass is defined as equipment made of Pyrex, borosilicate, and quartz glass used for scientific experiments. Examples of laboratory glass include beakers, flasks, graduated cylinders, stirring rods, test tubes, microscope slides, glass pipettes, petri dishes and glass vials. This waste should be disposed of in a cardboard lab glass box. *All glassware must be free of pourable liquid and must not contain sludges or caked solids. Glass items contaminated with biohazards are considered sharps waste (see paragraph above).*



Further details on how to manage sharps and lab glass waste can be found in the EH&S [Laboratory Sharps Fact Sheet](#).

### Peroxide Forming Chemicals

Ensure containers of peroxide forming chemicals are kept tightly sealed to avoid unnecessary evaporation, as this inhibits the stabilizers that are sometimes added. Visually inspect containers periodically to ensure they are free of exterior contamination or crystallization. *Dispose of containers of peroxide forming chemicals before their expiration date.*

If old containers of peroxide forming chemicals are discovered in the laboratory (greater than five years past the expiration date or if the expiration date is unknown), **do not handle the container**. If crystallization is present in or on the container, **do not handle the container**. *Secure the area and contact EH&S immediately.*

Picric acid (trinitrophenol) must be kept hydrated at all times, as it becomes increasingly unstable as it loses water content. **When dehydrated it is explosive and sensitive to shock, heat, and friction**. It is also highly reactive with a variety of compounds. All picric acid containers should be dated with the date received, and the water content monitored every 6 months. Add distilled water as needed to maintain a consistent liquid volume.

If old containers or containers of unknown provenance are discovered, **do not touch the container**. Even a minor disturbance could be very dangerous. Visually inspect the bottle. If there is even the slightest sign of crystallization in or on the bottle, or of evaporation, *secure the area and contact EH&S immediately.*

### Explosives and other Compounds with Shipping Restrictions

A variety of compounds that are classified as explosives (e.g. many nitro- and azo- compounds) or are water or air reactive are used in research laboratories. These compounds often have shipping restrictions and special packaging requirements, and may require stabilization prior to disposal. Consult with the Chemical Hygiene Officer for disposal considerations for these compounds.



### Controlled Substances

Waste containing intact controlled substances (e.g. expired ketamine) must be disposed of by DEA approved means. Contact the UCSB [Controlled Substances Program](#) for guidance.

### Empty Containers

Empty containers that held extremely hazardous materials, including extremely hazardous waste must be disposed of through EH&S, as these containers are regulated as hazardous waste. All other containers of less than or equal to 5 gallons should be reused for hazardous waste collection, recycled or disposed of. For more details, see the EH&S [Empty Containers Fact Sheet](#).

## Hazardous Waste Minimization

The UC Santa Barbara [Hazardous Waste Minimization Program](#) has the goal of reducing the amount and toxicity of waste generated through university activities. In addition to reducing risk to human health and the environment, waste minimization offers cost benefits in the form of avoided chemical purchasing and disposal costs. Some approaches to waste minimization include:

### Source Reduction

Changing practices and processes in order to reduce or eliminate the generation of hazardous waste is the best approach to waste minimization. This approach can include:

- **Effective Purchasing:** Order smaller volumes to avoid chemical expiration/degradation. Maintain an accurate chemical inventory to avoid duplicate orders.
- **Good Housekeeping:** Use a 'first in-first out' system in which the oldest chemicals are used first, to keep chemical stocks rotated.
- **Chemical Substitution:** Evaluate processes to determine whether a less hazardous chemical can be used in place of a more hazardous option.
- **Scale Reduction:** Reduce total volumes in experiments; employ microscale techniques where possible. Use instrumental analytical methods rather than wet chemical techniques.

### Recycling and Bench Top Treatment

When source reduction is not possible, recycling is the next best approach to waste minimization. Recycling of waste can take place both on and off campus and can include using a waste material for another purpose, treating a waste material and using it in the same process, or reclaiming a waste material for another process. Some examples include:

- Repurifying used solvents.
- Recirculating unused or surplus chemicals within your department or through the UCSB Surplus Chemicals program.
- Shipment of flammable liquid waste to offsite facilities, such as cement kilns, to be used as supplemental fuels.

Some waste can be treated to render it less or non-hazardous. Some examples include:

- Neutralizing acids and bases.
- Polymerizing acrylamide solutions.
- Oxidizing cyanide salts with bleach solutions.

- Charcoal filtration of ethidium bromide solutions.

Note: if treatment is not part of the end step of an experiment and is done separately from the experiment, it is considered hazardous waste treatment. This treatment activity requires a California Tiered Permit unless the activities comply with [Health and Safety Code 2200.3.1](#). As such, please contact EH&S if you plan to conduct any [bench-top treatment of waste](#).

## Chapter 4: Emergencies

Laboratory emergencies include events such as serious injuries, fires, explosions, spills, hazard exposures and natural disasters. All laboratory employees should be familiar with and aware of the location of the blue UCSB Emergency Flip Chart. This document has detailed response information for a wide variety of emergency situations. There should be one flip chart in every laboratory room or bay. Contact EH&S if additional copies of this document are needed. Before beginning any laboratory operation, ensure that there is a plan in place to deal with any potential emergency situations. Identify the location of safety equipment including first aid kits, eye wash/safety shower units, fire extinguishers, fire alarm pull stations, and spill kits. Know the locations of the nearest exits and telephones. See the following sections for more guidance on when an emergency response is warranted. However, *when in doubt, treat the situation as an emergency.*

If during an emergency or response, an unknown or hazardous chemical exposure occurs, an exposure assessment may be necessary. All applicable [exposure assessment protocols](#) will therefore be activated at that time.

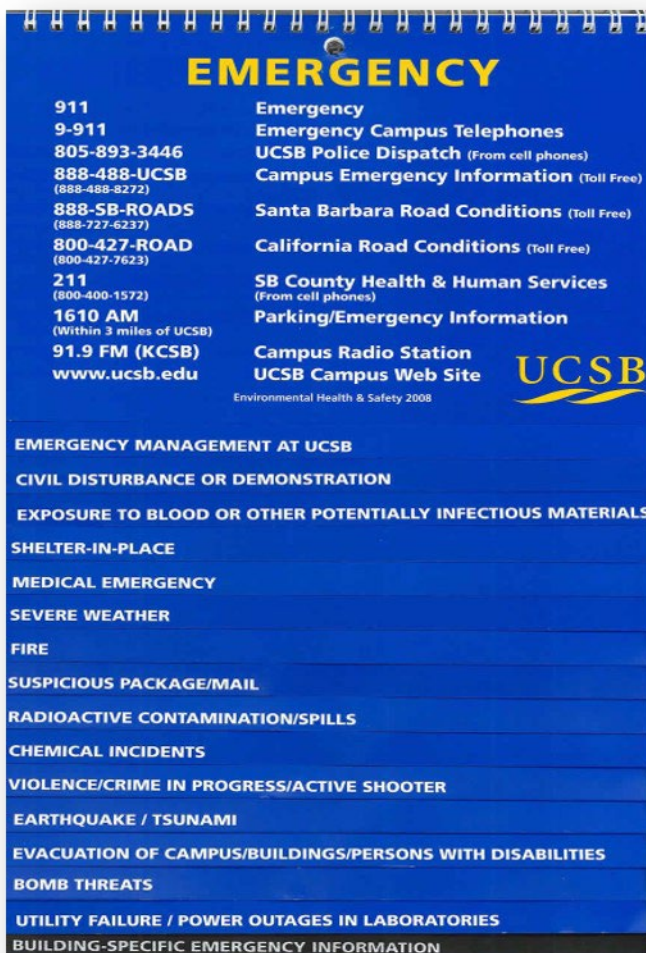

## Accidents

### TREATMENT:

## LABORATORY INJURY OR EXPOSURE

EMPLOYEES <small>(Getting paid by UC at time of incident)</small>	STUDENTS <small>(Getting paid by UC at time of incident)</small>	EVERYONE ELSE
<p style="text-align: center;"><b>Sansum Clinic Occupational Medicine</b></p> <p style="text-align: center;">(805) 898-3311 101 S Patterson Ave</p> <p style="text-align: center;">Weekdays 8 am to 5 pm</p>	<p style="text-align: center;"><b>Student Health</b></p> <p style="text-align: center;"><small>(805) 893-7129 or (805) 893-3371 Located on El Colegio and Mesa Rds., across from the Events Center.</small></p> <p style="text-align: center;">Weekdays 9 am to 4:30 pm</p>	<p style="text-align: center;">Go to your personal medical provider</p>

**AFTER HOURS AND IMMEDIATE TREATMENT FOR EVERYONE**

URGENT CARE	Goleta Valley Cottage Hospital	Santa Barbara Cottage Hospital
<p style="text-align: center;"><small>(805) 563-6110</small></p> <p style="text-align: center;">Sansum Clinic, 215 Pesetas Lane</p> <p style="text-align: center;">Monday - Friday, 8:00am - 7:00pm Saturday, 9:00am - 5:00pm Sunday, 9:00am - 3:00 pm</p> <p style="text-align: center;"><small>(USE ONLY WHEN PATTERSON OFFICE IS CLOSED)</small></p>	<p style="text-align: center;"><small>(805) 967-3411</small></p> <p style="text-align: center;">351 S. Patterson Ave</p> <p style="text-align: center;">Open 24 hours</p> <p style="text-align: center;"><small>(USE FOR EMERGENCIES)</small></p>	<p style="text-align: center;"><small>(805) 682-7111</small></p> <p style="text-align: center;">Pueblo at Bath</p> <p style="text-align: center;">Open 24 hours</p> <p style="text-align: center;"><small>(USE FOR EMERGENCIES)</small></p>

### NOTICES

**Explain Exposure:** Be prepared to communicate exposure details (e.g., chemical name, biohazard) to medical providers.  
**Transportation:** Arrange an escort when possible. For non-emergencies, you may use a personal vehicle instead of taking an ambulance.  
**Report:** Work related injury/illness claims should be filed as soon as possible at [ehs.ucop.edu/efr](https://www.ehs.ucop.edu/efr)  
 For students fill out Notice of Incident Form available at <https://www.ehs.ucsb.edu/>  
 Near miss report form available at <https://www.ehs.ucsb.edu/>

**CALL 911 IF EMERGENCY OR LIFE THREATENING**

- Laboratory employees who are injured or ill should notify their PI/Laboratory Supervisor immediately, and then seek medical attention if needed. **When in doubt, seek medical attention.**
- Each laboratory should prepare for emergencies by, at minimum:
  - Access to a first aid kit.
  - Posting of emergency telephone numbers and locations of [emergency treatment facilities and occupational health facilities](#).
  - Training of staff to:

- Assist injured personnel with the emergency eyewash/shower and ensure that they flush exposed areas for a full 15 minutes.
- Accompany injured personnel to the medical treatment site and to provide medical personnel with copies of Safety Data Sheets (SDS) for the chemicals involved in the incident.

If an employee has a severe or life threatening injury, call for emergency response. Employees with minor injuries should be treated with first aid kits and sent to [Sansum Clinic Occupational Medicine](#). If the lab worker is a student (i.e. not on UCSB payroll), then they should go to [Student Health](#) for service. After normal business hours, treatment can be obtained at Goleta Valley or Santa Barbara Cottage Hospital.

#### REPORTING:

- PIs/Laboratory Supervisors are responsible for ensuring that their employees receive appropriate medical attention in the event of an occupational injury or illness. The PI/Laboratory Supervisor should call Workers' Compensation (805-893-4440) immediately if an employee seeks medical treatment, followed by creating a claim through the [Employee First Report \(EFR\)](#) system.
- **Serious occupational injuries, illnesses, and exposures to hazardous substances must be reported to EH&S at 805-893-3194 within 8 hours.** EH&S is required to report these events to Cal/OSHA, and will also investigate the accident and complete exposure monitoring as necessary. Serious injuries are defined as those that result in permanent impairment or disfigurement, or require hospitalization. Examples include amputations, lacerations with severe bleeding, burns, concussions, fractures and crush injuries.

## Laboratory Safety Equipment

New personnel must be instructed in the location and use of fire extinguishers, safety showers, and other safety equipment *before* they begin work in the laboratory. This training is part of the required laboratory specific training that is documented on the [Training Needs Assessment Form](#). Hands-on fire extinguisher training is provided during the live Fundamentals of Laboratory Safety course, as well as upon request.

## Fire Extinguishers

All laboratories working with combustible or flammable chemicals must be outfitted with appropriate fire extinguishers. All extinguishers should be wall-mounted in an area free of clutter, or stored in a fire extinguisher cabinet. Research personnel should be familiar with the location, use and classification of the extinguishers in their laboratory. Laboratory personnel are *not required* to extinguish fires that occur in their work areas and should not attempt to do so unless:

- It is a small fire (small trash can-sized or smaller).
- Hands-on fire extinguisher training has been received.
- It is safe to do so.
- The individual wishes to do so.

Any time a fire extinguisher is discharged, no matter what the reason or how brief a period, EH&S must be contacted. Once partially discharged, an extinguisher will lose pressure quickly and therefore must be replaced as soon as possible.

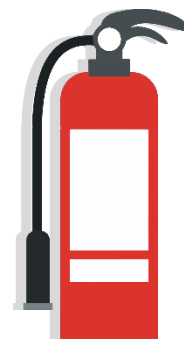

## Safety Shower/Eyewash Stations

All laboratories using hazardous chemicals must have immediate access to safety shower/eyewash stations. Access must be available in 10 seconds or less for a potentially injured individual, and access routes must have no more than one intervening door, opening in the direction of travel, and must be kept clear at all times. Safety showers require a minimum clearance of 16 inches from the centerline of the spray pattern in all directions and at all times. *Therefore, no objects should be stored within 16 inches of a safety shower.* Sink-based eyewash stations and drench hoses are not adequate to meet this requirement and can only be used to support an existing compliant system.

In the event of an emergency, individuals using the safety shower should be assisted by an uninjured person to aid in decontamination, and should be encouraged to stay in the shower for a full 15 minutes.

Safety shower/eyewash stations are tested by Facilities Management on a monthly basis. If a safety shower/eyewash unit appears to need repair, call Facilities Management Customer Service at 805-893-8300.

## Fire Doors

Research buildings contain critical fire doors as part of the building design. As an important element of the building fire containment system, these doors shall remain closed unless they are held open by an electromagnetic releasing system integrated with the building fire detection system. Never use door stops to hold fire doors open.

## Fire-Related Emergencies

If you encounter a fire, or a fire-related emergency (e.g. abnormal heating, smoke, burning odor), immediately follow these instructions:

- Pull the closest fire alarm pull station and call 911 to notify the Fire Department.
- Evacuate and isolate the area. Close all doors. Shut off equipment if feasible.
- Remain safely outside the affected area to provide details to emergency responders (do not leave).



If you hear a fire alarm sound, evacuate the building. *It is against state law to remain in the building when the alarm is sounding, even if it is a false alarm or drill.*

Do not reenter the building until the alarm stops and you are cleared to reenter by Fire Department personnel.

*If your clothing catches fire, go to the nearest emergency shower and activate the water flow. If the shower is more than 3 steps away, Stop, Drop and Roll, then proceed to the nearest shower to cool off.* A fire extinguisher may be used to extinguish a fire on someone's person. Report any burn injury to your supervisor immediately and seek medical treatment.

## Chemical Spills

**For all spill releases occurring during regular work hours (8:00am-5:00pm), notify EH&S at (805)893-3194 immediately, regardless of whether you require clean-up assistance. After hours, if the spill is not easily contained, or if you are concerned about the health and safety of yourself and others, call 911.** Otherwise notify EH&S at (805)893-3194 as described above.

Chemical spills can result in chemical exposures and contaminations. Chemical spills become emergencies when:



- The spill results in injury and/or a release to the environment (e.g. via a sink or floor drain).
- The material or its hazards are unknown.
- Laboratory personnel cannot safely manage the situation due to high hazard or volumes greater than one liter.

Effective response to chemical spills is necessary to minimize adverse outcomes such as injury, illness, or environmental damage. After emergency procedures are completed, all personnel involved in the incident should follow UCSB chemical exposure procedures as appropriate (see [Chemical Exposures: Limits, Assessments, and Medical Evaluations](#) in Chapter 3 of this document). Some key factors to consider before initiating a spill clean-up include:

- Location
- Volume/size of spill area
- Toxicity
- Volatility
- Flammability and presence of ignition sources
- Availability of spill cleanup materials, including proper PPE
- Training of responders

**NOTE: HIGHLY HAZARDOUS CHEMICAL SPILLS**

**Do not clean up spills of any size of the following chemicals:**

<ul style="list-style-type: none"> <li>• <b>Aromatic amines</b></li> <li>• <b>Carbon disulfide</b></li> <li>• <b>Cyanides</b></li> <li>• <b>Ethers</b></li> <li>• <b>Mercury</b></li> </ul>	<ul style="list-style-type: none"> <li>• <b>Hydrazine</b></li> <li>• <b>Hydrofluoric acid</b></li> <li>• <b>Nitriles</b></li> <li>• <b>Nitro compounds</b></li> <li>• <b>Organic halides</b></li> </ul>
---	---

**Spills of these chemicals require emergency response.**

**Evacuate, isolate the area and contact EH&S.**

#### **Small Chemical Spill Procedure (< 1 Liter)**

If a spill is up to 1 liter in size and of limited toxicity, flammability and volatility, laboratory members may choose to effect clean-up if trained to do. EH&S may be called for spills of < 1 liter. If laboratory personnel choose to clean the spill, the following procedure should be followed:

- Evacuate all non-essential persons from the spill area.
- If needed, call for medical assistance by calling 911.
- Help anyone who may have been contaminated. Assist with shower/eyewash as needed.

- Post someone just outside of the spill area to keep people from entering.
- Turn off all ignition sources, and close valves on compressed gas cylinders of flammable gas.
- Don proper PPE: Safety goggles, laboratory coat, shoe covers and appropriate gloves at minimum. Check the SDS for spill clean-up procedures including necessary PPE or call EH&S.
- Avoid breathing vapors from the spill. If the spill is in a non-ventilated area, do not attempt the clean-up. Evacuate, isolate the area and call EH&S.
- Confine the spill to as small an area as possible by treating it from the outside edges in.
- Do not clean up the spill alone. Use the buddy system.
- Do not add water to the spill.
- To clean up a spill of weak inorganic acid or base, neutralized the spilled liquid to pH = 5-8 us in a neutralizing agent such as sodium bicarbonate, sodium bisulfate, or soda ash for spilled acids, or citric acid for spilled bases. For solvent spills skip to the next step.
- Absorb the neutralized liquid or solvent with an absorbent such as sorbent pads, sponges, paper towels, dry sand or diatomaceous earth.
- Collect the absorbents and place in a clear plastic bag. Double bag the waste and attach a completed [hazardous waste label](#) to the bag. Transport to the waste pickup area and [schedule a pickup](#).

### **Large Chemical Spill Procedure (> 1 Liter)**

If the spill presents a situation that is immediately dangerous to life or health or presents a significant fire risk, activate a fire alarm, evacuate the area, call 911 and wait for emergency response to arrive.

Otherwise

- Remove any injured and/or contaminated person(s) and provide first aid.
- Call for emergency medical response if needed.
- As you evacuate the laboratory, close the door behind you, and:
  - Post someone safely outside and away from the spill area to keep people from entering.
  - Confine the spill area if possible and safe to do so.
  - Leave on or establish exhaust ventilation

- If possible, if the material is flammable, turn off or remove all ignition sources.
  - Avoid walking through contaminated areas or breathing vapors of the spilled materials.
- Any employee with known contact with a particularly hazardous chemical must shower, including washing of hair, as soon as possible unless contraindicated by physical injuries.

### **Chemical Exposure to Personnel**

In the event of a significant chemical exposure:

- immediately try to remove or isolate the chemical if safe to do so.
- When skin or eye exposures occur, remove contaminated clothing and flush the affected area using an eyewash/shower unit *for at least 15 minutes*.
- Remember to wear appropriate PPE when helping others.
- For a non-emergency chemical ingestion, inhalation or dermal exposure contact the [California Poison Control System](#) at 1-800-222-1222 for assistance, and seek medical care as instructed.

PLS/Laboratory Supervisors must review all exposure situations, make sure affected employees receive appropriate medical treatment and/or assessment, and arrange for containment and clean-up of the chemical as appropriate (either by laboratory personnel or by contacting EH&S).

## Earthquake

In the event of an earthquake, please take the following precautions:

- Prepare in advance: be familiar with your department's Emergency Action Plan.
- Take cover under a desk or strong doorframe during the shaking.
- Remain under cover indoors until the shaking subsides. Evacuate the building only once the shaking has ceased. Proceed to your building's emergency assembly point.
- Report any injuries or broken utility services to 911.
- Assist any injured individuals with receiving medical attention.

## Chapter 5: Compliance

### Recordkeeping Requirements

Accurate recordkeeping demonstrates a commitment to the health and safety of the UC Santa Barbara community, integrity of research, and protection of the environment. EH&S is responsible for maintaining records of the Laboratory Safety Reviews, all laboratory audits and surveys, accident investigations, monitoring equipment calibration and exposure assessment data, inventory and use records for high-hazard materials, any medical consultation and examination records, including test or written opinions, and training conducted by EH&S staff or on line. Per Cal/OSHA regulations, departments or laboratories are responsible for documenting departmental or lab specific health and safety training. The [Training Needs Assessment Form](#) is a useful tool for documenting each person's training record.

### Notification and Accountability

PI's/Laboratory Supervisors are responsible for taking appropriate and effective corrective action upon receipt of written notification of findings requiring resolution that are identified via lab safety reviews, audits, surveys or inspections. Findings are assigned one of four priority levels, each with its own timeframe for resolution:

**Imminent Danger** (Immediate danger to life and health, significant property damage, serious near-miss incidents involving conditions that are likely present in other locations on campus.): Immediate Resolution/Stop Work.

**Priority One** (Serious safety hazard, serious/willful regulatory violations and/or significant fire and life safety code violation): Closure within 0-5 days

**Priority Two** (Moderate safety hazard or moderate/repeat regulatory violation and/or moderate fire and life safety concern/housekeeping/documentation issues, etc.): Closure within 6-30 days

**Priority Three:** Closure within 31-90 days (minimal safety hazard/ possible regulatory violation, infrastructure, deferred maintenance, etc.)

The determination of prioritization is subjective based on the inspector's judgment. Every situation is unique; EHS inspectors will base inspection findings on a review of relevant hazards, codes and exposures.

### Compliance Procedures

Reminder emails will be sent to the PI/Laboratory Supervisor after the initial report is sent. Repeat issue of non-compliance, identified via scheduled inspection or otherwise, include but are not limited to:

- Any Serious (Priority 2) findings that have not been corrected within 30 calendar days of the initial report of non-compliance.
- Any urgent (Priority 1) findings that have not been corrected within 5 days of the initial report on non-compliance.

When the above conditions are met, the following escalation protocols are initiated:

### **Priority 2 (Serious) Escalation Protocol**

Escalation 1: Email notification sent to Department Chair at 4 weeks:

*Dear Prof. [ ],*

*This letter is to inform you that Prof. [ ] has outstanding serious findings in the most recent Environmental Health and Safety laboratory inspection. Our standard practice for serious findings is to remind the responsible party to correct the findings and update the INSPECT database twice, in two week intervals, before escalating the issue to the department chair. That period has now expired.*

*Please remind Prof [ ] that addressing safety issues and documenting corrections is a key part of sustaining a safe and compliant laboratory culture, and request that they complete the corrections and update the INSPECT database as soon as possible.*

*Thank you,*

Escalation 2: Email to Department Chair at 6 weeks:

*Dear Prof. [ ],*

*This letter is to inform you that Prof. [ ] still has outstanding serious findings in the most recent Environmental Health and Safety laboratory inspection. This is our second notification to you regarding this issue. Our standard practice in this situation is to send a second notification to the department chair, followed by escalation to the Dean if the matter is not resolved within two weeks of this notice.*

*Please remind Prof [ ] that addressing safety issues and documenting corrections is a key part of sustaining a safe and compliant laboratory culture, and request that they complete the corrections and update the INSPECT database as soon as possible.*

*Thank you,*

Escalation 3: Email to Dean at 8 weeks:

*Dear Dean [ ],*

*This letter is to inform you that Prof. [ ] has outstanding serious findings in the most recent Environmental Health and Safety laboratory inspection. Our standard practice for serious*

*findings is to remind the responsible party to correct the findings and update the INSPECT database twice, in two week intervals, before escalating the issue to the department chair. As the matter is still not resolved upon contacting the department chair, we are reaching out to you for assistance in getting this matter resolved.*

*Please remind Prof [ ] that addressing safety issues and documenting corrections is a key part of sustaining a safe and compliant laboratory culture, and request that they complete the corrections and update the INSPECT database as soon as possible.*

*Thank you*

Escalation 4: Refer the issue to the Chemical and Physical Hazard Safety Committee.

### **Priority 1 (Urgent)**

Escalation 1: Email to Department Chair at 5 days:

*Dear Prof. [ ],*

*This letter is to inform you that Prof. [ ] has outstanding urgent findings in the most recent Environmental Health and Safety laboratory inspection. Our standard practice for urgent findings is to remind the responsible party to correct the findings and update the INSPECT database once, five days after the initial notification, before escalating the issue to the department chair. That period has now expired.*

*Please remind Prof [ ] that addressing safety issues and documenting corrections is a key part of sustaining a safe and compliant laboratory culture, and request that they complete the corrections and update the INSPECT database as soon as possible. The matter will be escalated to the Dean if the matter is not resolved within two days of this notice.*

*Thank you,*

Escalation 2: Email to Dean at 7 days:

*Dear Dean [ ],*

*This letter is to inform you that Prof. Y has outstanding urgent findings in the most recent Environmental Health and Safety laboratory inspection. Our standard practice for urgent findings is to remind the responsible party to correct the findings and update the INSPECT database five days after the initial notification, before escalating the issue to the department chair. As the matter is still not resolved upon contacting the department chair, we are reaching out to you for assistance in getting this matter resolved.*

*Please remind Prof [ ] that addressing safety issues and documenting corrections is a key part of sustaining a safe and compliant laboratory culture, and request that they complete the corrections and update the INSPECT database as soon as possible.*

*Thank you,*

Escalation 3: Refer the issue to the Chemical and Physical Hazard Safety Committee.

## Acknowledgements

UC Santa Barbara would like to thank the UCLA Office of Environmental Health & Safety. This document was created using the UCLA Chemical Hygiene Plan 2019 as a major source of content.

This document was reviewed, edited and approved by the UC Santa Barbara Chemical and Physical Hazards Safety Committee, Prof. Christopher Palmstrøm, Chair.